

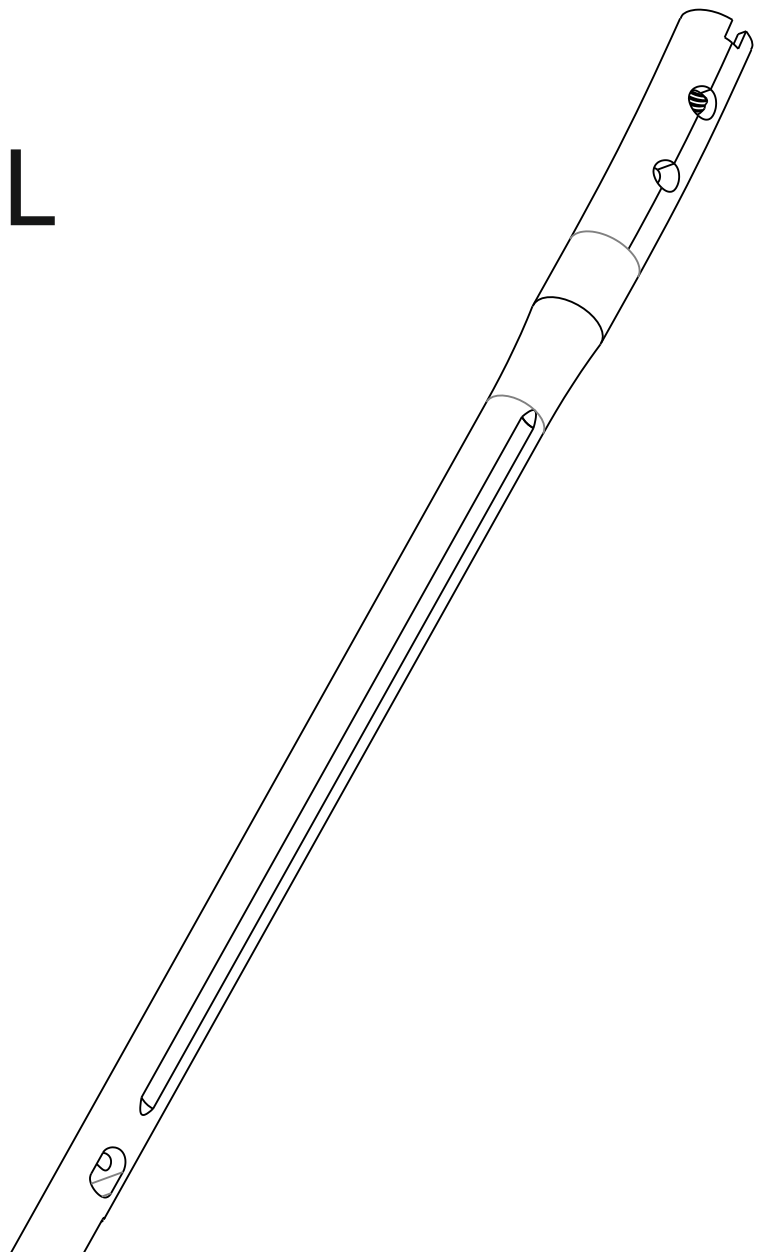

[www.osteofrance-ortho.fr](http://www.osteofrance-ortho.fr)



Cannulated Intramedullary  
**RETROGRADE  
FEMORAL NAIL**  
Surgical Technique



Cannulated Intramedullary  
**RETROGRADE  
 FEMORAL NAIL**  
 Surgical Technique

CONTENS

**1. Introduction**

1.1. Retrograde Femoral Nail.....	3
1.1.1. Specification .....	

**2. Surgical Technique**

2.2. Retrograde Femoral Nail.....	4
2.2.1. Determine entry point.....	4
2.2.2. Open Medullary Canal-AWL.....	4
2.2.3. Nail Insert.....	5
2.3.4. Proximal Screw for the nail.....	5
2.3.5. Guide bar and distal locking device.....	5
2.3.6. Distal locking device.....	10
2.3.7. Screw for the distal (Nail).....	10
2.3.7. Finishing.....	10

**3. Instrument Set**

3.1. Tray 1 .....	11
3.2. Tray 2.....	
3.2. Tray 3 .....	

**4. Disinfection**

4.1. Device Cleaning Conditions.....	14
4.1.1. Manual Cleaning/Disinfection.....	
4.1.2. Combination Manual / Automated Cleaning.....	
and Disinfection:.....	
4.1.3. Automated Cleaning and Disinfection .....	





## 1.1. Retrograde Femoral Nail

### Specifications

In order to use different entry sites in multiple injuries, e.g. patient with ipsilateral acetabular fractures or bilateral femur fractures, and less exposure to radiation during pregnancy, due to difficulties arising from the access site and surgical technique in the treatment of ipsilateral femoral neck fractures, trochanteric fractures in morbid, obese patients

is preferred for Diameter sizes between  $\varnothing$  9,10,11,12,13 mm and length options between 180-360 mm are available. The nail and all its components are produced from Ti 6AL4V ELI material.

### Cannulated Intramedullary RETROGRADE FEMORAL NAIL

REF. NO	SIZE	REF. NO	SIZE
4122-0918	9x180	4122-1126	11x260
4122-0920	9x200	4122-1128	11x280
4122-0922	9x220	4122-1130	11x300
4122-0924	9x240	4122-1132	11x320
4122-0926	9x260	4122-1134	11x340
4122-0928	9x280	4122-1136	11x360
4122-0930	9x300	4122-1218	12x180
4122-0932	9x320	4122-1220	12x200
4122-0934	9x340	4122-1222	12x220
4122-0936	9x360	4122-1224	12x240
4122-1018	10x180	4122-1226	12x260
4122-1020	10x200	4122-1228	12x280
4122-1022	10x220	4122-1230	12x300
4122-1024	10x240	4122-1232	12x320
4122-1026	10x260	4122-1234	12x340
4122-1028	10x280	4122-1236	12x360
4122-1030	10x300	4122-1318	13x180
4122-1032	10x320	4122-1320	13x200
4122-1034	10x340	4122-1322	13x220
4122-1036	10x360	4122-1324	13x240
4122-1118	11x180	4122-1326	13x260
4122-1120	11x200	4122-1328	13x280
4122-1122	11x220	4122-1330	13x300
4122-1124	11x240	4122-1332	13x320

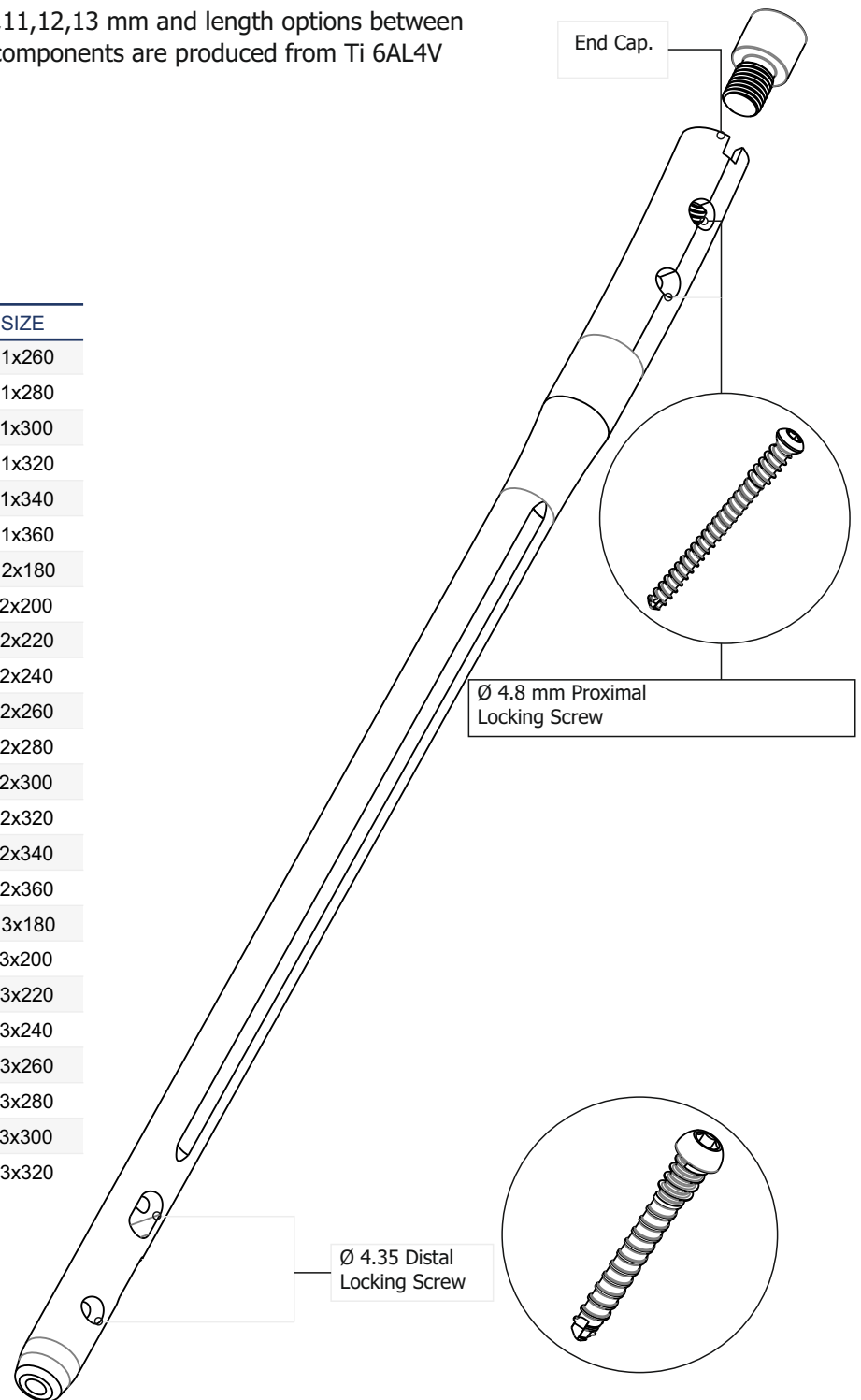



### 2.2.1. Determine entry point



*The Femoral Nail is in line with the medullary canal. the important thing at the apex of the intercondylar notch, only anterior and lateral to the femoral attachment of the posterior cruciate. The entry point is especially for the optimal end position of the nail. It is decisive for the whole operation according to the anatomical conditions*

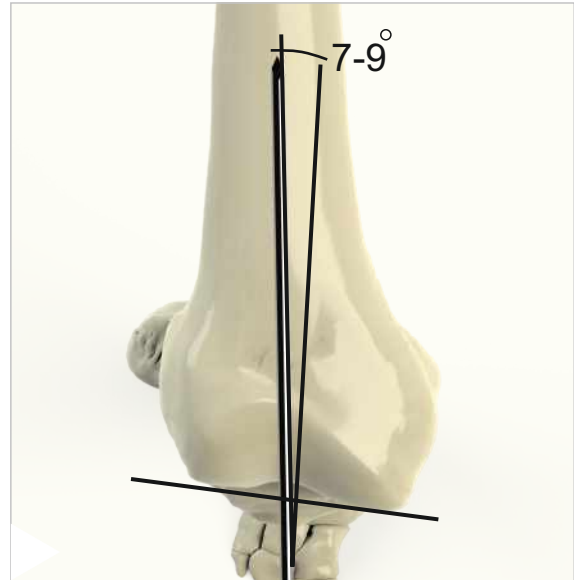

Insert the guide wire for approximately 10 to 15 cm in line with the anatomic axis of the femur, which is 7 to 9° in valgus,

### 2.2.2. Open medullary canal – awl



The awl may be used to open the medullary canal.  
Remove the protection sleeve.  
Push the awl over the guide wire and open the medullary canal



### 2.2.3.Nail Insert

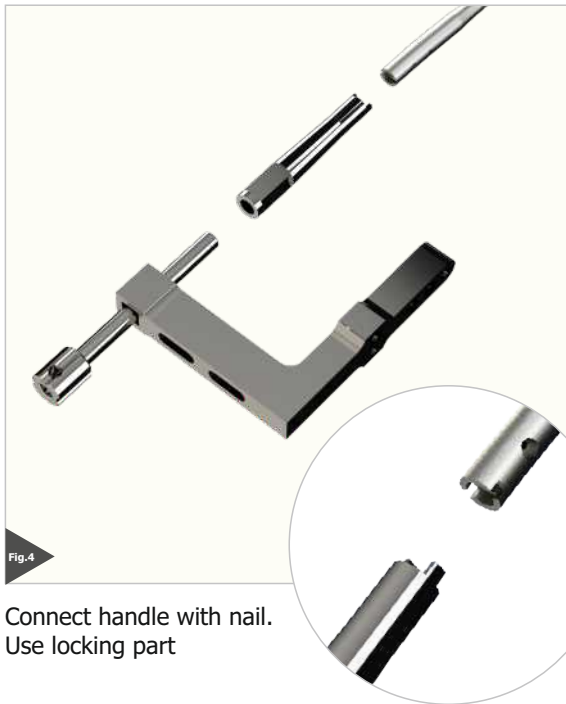

Connect handle with nail.  
Use locking part



the nail is ready to be sent through the drilled hole.  
Advance a little with the holder.



Attach the sliding hammer to handle. Advance the  
nail in the canal with a back and forth hand motion



The nail is placed in the canal. Screws proximal to  
the nail will be inserted using the screw holes on the  
holder.



## 2.2.4. Proximal Screw for the nail



Guides are installed first. Then the location is determined with the marker.



Then the location is determined with the marker.



Insert drill guide and drill for Ø4.8 screw



Screws whose size is determined are placed with a T screwdriver. Tube guides are removed.



## 2.2.5. Guide bar and distal locking device



The guide bar is adjusted according to the length of the nail and mounted on the holder.



The necessary part is attached to fix the distal of the nail.



tube guide is attached



identify the drilling location with the marker



## 2.2.6. Distal locking device

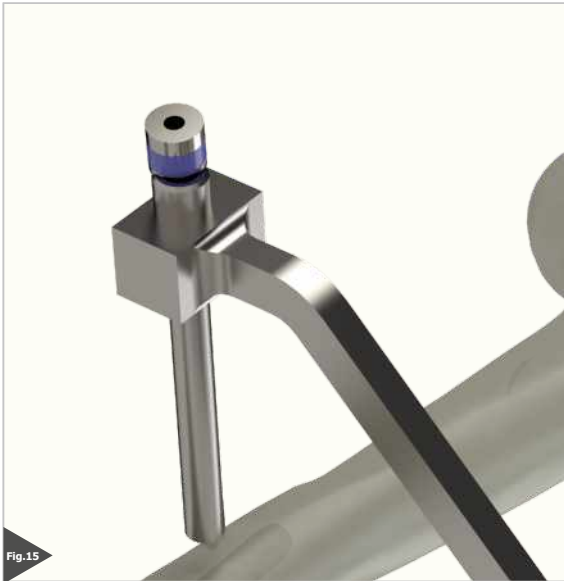

Install the drill guide



Make the drilling from guide



Perform the distal locking of the nail using the distal locking pieces.



Insert tube guides into the holes on the guide bar



## 2.2.7. Screw for the distal (Nail)



Identify with the marker



Insert the drill guide

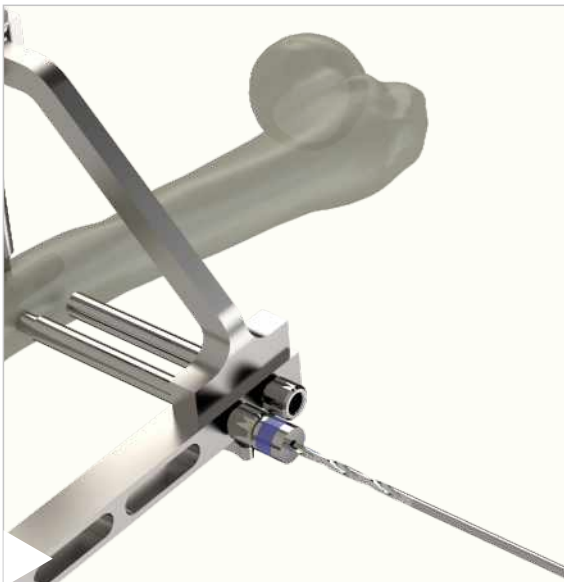

Do the Drilling



Determine the screw length with the help of a length gauge



## 2.2.8. Finishing



Send the screws of which you have determined the length from the guides with a t screwdriver.



The stability of the nail is complete. Remove the guide bars and attach the End Cap to complete the process.

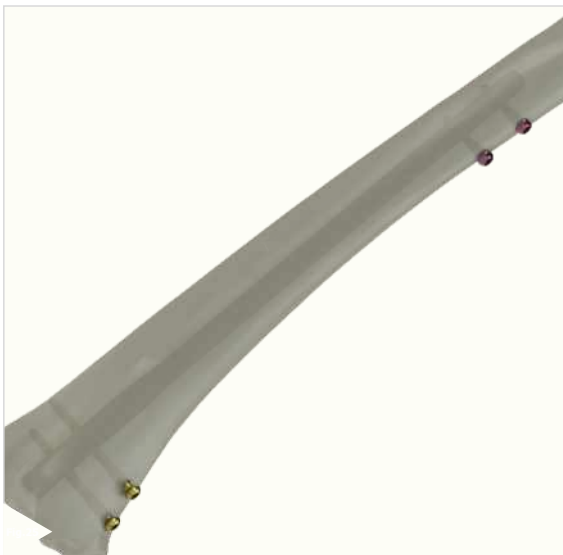



### 3. Retrograde Femoral Nail Instrument

#### 3.1. Tray 1

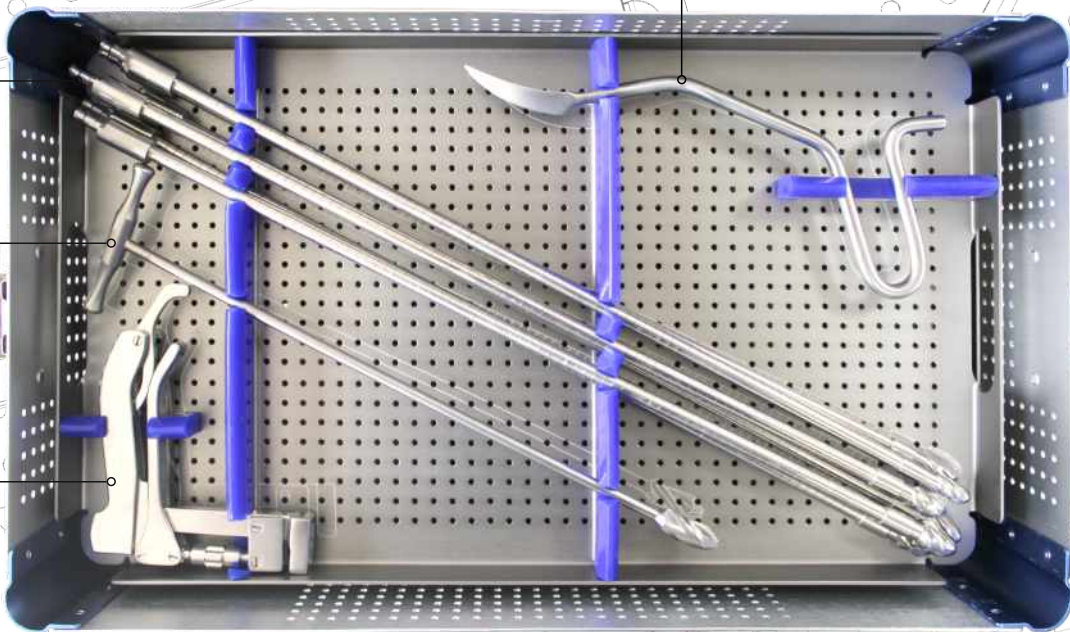

<b>1</b>	9412-0013	Gripper
<b>2</b>	9412-0013a	T Reamer
<b>3</b>	9412-0033	Cannulated Flexible Reamer
<b>4</b>	9412-0015	Pointed AWL



## 3. Retrograde Femoral Nail Instrument

### 3.3. Tray 3

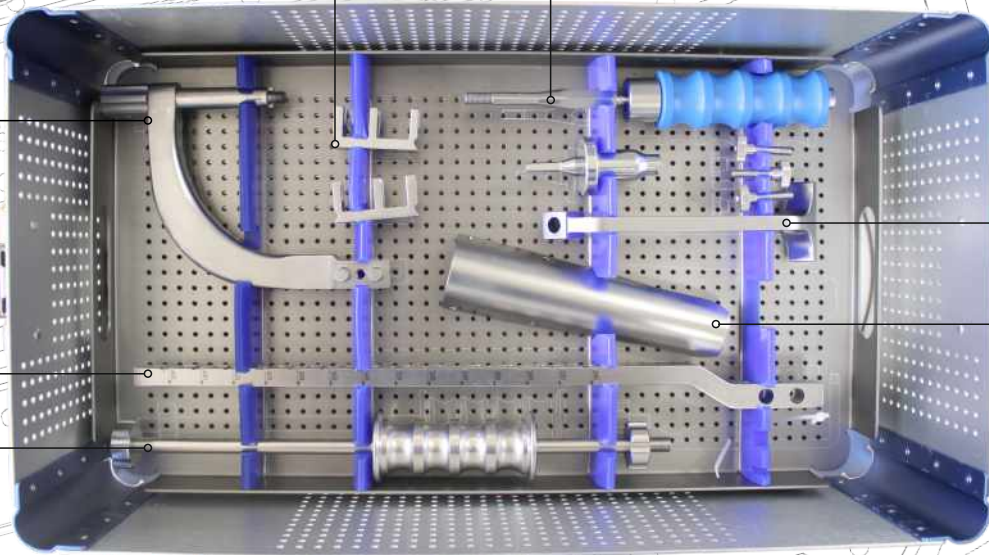

<b>21</b>	9412-0008	Cannulated Sliding Hammer
<b>22</b>	9412-0012	Guide Bar
<b>23</b>	9412-0011	Nail Support Handle
<b>24</b>	9412-0009	U-Stabilizing Spacer
<b>25</b>	9412-0001	Screw Adapter
<b>26</b>	9412-0004	Proximal Outrigger



### 3. Retrograde Femoral Nail Instrument

#### 3.2. Tray 2

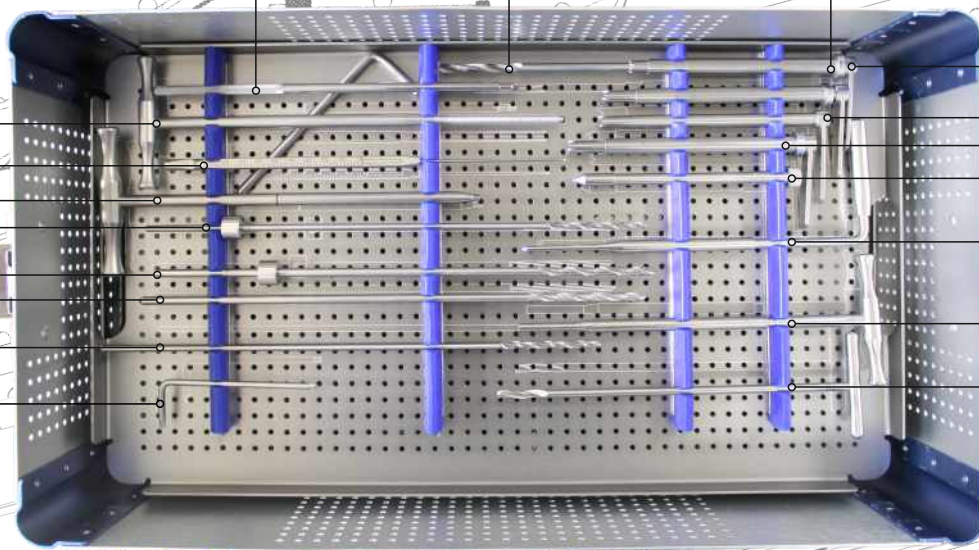

5	9412-0008	Wrench 5 mm
6	9412-0025	Drill Ø 3.5 mm
7	9412-0026	Drill Ø 4 mm
8	9412-0018	Screwdriver
9	9412-0019	Depth Guide
10	9412-0016	Tap
11	9412-0017	Locking Screw Extractor
12	9412-0028	Drill Ø 5 mm
13	9412-0022	Screw Guide Ø 10 / Ø 8 mm
14	9412-0021	Drill Guide Ø 8 / Ø 5 mm
15	9412-0023	Drill Guide Ø 8 / Ø 4 mm
16	9412-0024	Drill Guide Ø 8 / Ø 3.5 mm
17	9412-0014	Obturator
18	9412-0005	Graduated Angled Trocar
19	9412-0030	Stabilizing Rod
20	9412-0003	T Handle Reamer
21	9412-0013	Gripper
22	9412-0013a	T Reamer



## 4.1 DEVICE CLEANING CONDITIONS

Do not use metal brushes or rubbing pads during Decontamination of the tools should be performed immediately after the surgical procedure is completed. Contaminated tools must not be allowed to dry before reprocessing.

Excessive blood or debris must be removed in order to prevent the drying on the surface. All users must be qualified staff with documented evidence of training and competence. Training should include the current guidelines, standards and hospital policies. Even if they are made of high-grade stainless steel, the surgical tools must be thoroughly dried in order to prevent rust formation. Prior to sterilization, all the tools should be examined for the cleanliness of the lumens of the joints of the surfaces. manual cleaning process. Use cleaning agents with low-foam surfactant to be able to see the tools in the cleaning solution. Rinse the cleaning materials easily from the tool in order to prevent residue formation.

Mineral oil or silicon lubricants should not be used

materials are recommended for cleaning the reusable instruments. It is very important to neutralize and rinse the alkaline cleaning materials thoroughly from the tools. Anodized aluminum should not contact with certain cleaning or disinfectant solutions. Avoid strong alkaline cleaners and disinfectants and solutions containing iodine, chlorine or certain metal salts.

### Manual Cleaning/Disinfection

Prepare the enzymatic and cleaning materials at the dilution rates and temperatures as recommended by the manufacturer. New solutions should be prepared when the existing solutions are heavily contaminated. Place the tools in the enzymatic solution so that they are completely immersed. Operate all the movable parts so that the detergent contacts with all the surfaces.

Keep in the fluid for minimum 20 min. Use a nylon, soft-bristled brush to gently rub the tools until all visible debris is cleaned. Pay particular attention to the accessible areas and use a suitable bottle brush. In order to remove the dirt in the open springs, coils or flexible parts, wash the recesses with plenty of cleaning solution. Rub the surface with a scrubbing brush to remove all the visible dirt from the surface and the recesses. To ensure that all the recesses are cleaned, turn the component while rubbing. Remove the tools and rinse them for minimum 3 min. under running water. Pay particular attention to the cannulas and use a syringe to pass the fluid through the hard-to-reach areas. Place all the tools that are completely immersed in water, in an ultrasonic unit containing the cleaning solution. Operate all the movable parts so that the detergent contacts with all the surfaces. Expose the tools to sonification process for minimum 10 min..

Remove the tools and rinse with deionized water for at least 3 minutes or unless all the blood or dirt traces are eliminated in the rinsing water. Examine the tools under normal light to verify that visible dirt is removed. If

visible dirt is present, repeat the above mentioned sonification procedure and the rinsing steps. Remove the excessive moisture on the tool with a clean, absorbent, lint-free cloth.

### Combination Manual / Automated Cleaning and Disinfection

Prepare the enzymatic and cleaning materials at the dilution rates and temperatures as recommended by the manufacturer. New solutions should be prepared when the existing solutions are heavily contaminated. Place the tools in the enzymatic solution so that they are completely immersed. Operate all the movable parts so that the detergent contacts with all the surfaces. Keep in the fluid for minimum 10 min. Use a nylon, soft-bristled brush to gently rub the tools until all visible debris is cleaned. Pay particular attention to the accessible areas and use a suitable bottle brush. A sonicator will help to clean the instruments thoroughly. The use of a syringe or a water fountain will facilitate passing of the liquid from the low-spaced areas and difficult-to-access areas. Remove the tools from the enzyme solution and rinse them for minimum 1 min. under deionized water. Place the tools in a suitable washer / disinfectant basket and perform a standard washer / disinfectant cycle. Specific minimum parameters are essential for a complete cleaning and disinfection. These parameters are given in a below mentioned table.



### Automated Cleaning and Disinfection

Automated washing / drying systems are not recommended as the only cleaning method for surgical tools. An automated system can be used as a follow-up operation after manual cleaning. To ensure an effective cleaning, tools must be thoroughly examined before sterilization. For detailed information on Washing and Disinfection see

### Specific minimum parameters used for a complete cleaning and disinfection:

	Definition
1	Pre-washing for 2 minutes with cold tap water
2	enzyme spray for 20 seconds with hot tap water
3	Immersion in enzyme after 1 minute
4	rinsing for 15 seconds with cold tap water (Should be repeated twice)
5	Washing with detergent for 2 minutes with hot tap water
6	rinsing for 15 seconds with hot tap water
7	Rinsing with 10 seconds with optional lubricated purified water
8	Drying for 7 minutes with hot air

Note: Follow the instruction of the washer/disinfectant manufacturer

●  **Medical**, as the manufacturer of this device, and their surgical consultants do not recommend this or any other surgical technique for use on a specific patient. The surgeon who performs any implant procedure is responsible for determining and utilizing the appropriate techniques for implanting the device in each individual patient.  and their surgical consultants are not responsible for selection of the appropriate surgical technique to be utilized for an individual patient.