

**ce Ortho**

[www.osteofrance-ortho.fr](http://www.osteofrance-ortho.fr)

# ZFN MULTI-PURPOSE FEMORAL NAIL

Surgical Technique





# Contents

## 1. Introduction

1.1. Femoral Nail.....	
1.1.1. Specification.....	

## 2. Surgical Technique

2.1. Fractures .....	
2.1.1. Subtrochanteric Femur Fractures.....	
2.1.2. Femur Shaft Fractures.....	
2.2. Preparation.....	
2.2.1. Determining Nail Length .....	
2.2.2. Determine Entry Point .....	
2.2.2.1 Great Trochanter.....	
2.2.2.2 Piriformis Fossa.....	
2.3. Medullary Canal.....	
2.3.1. Entry opening.....	
2.3.2. Reaming Canal.....	
2.4. Nail .....	
2.4.1. Placement Of the Nail.....	
2.5. Locking.....	
2.5.1. Proximal Locking.....	
2.6. Proximal Screw.....	
2.6.1. Screw Location.....	
2.6.2. Determine Screw Length.....	
2.6.3. Drilling .....	
2.6.4. Ø6.4mm Lag Screw .....	

2.7. Locking 2 .....	15
2.7.1 Distal Locking.....	
2.8. Distal Screw.....	19
2.8.1 Drilling.....	
2.8.2 Determine Screw Length & Ø4.8mm Screw.....	
2.8.3 Ø4.8mm Screw.....	
2.9. Finishing.....	22
2.9.1. Removing Targeting Device.....	
2.9.2 End Cap.....	
2.8.3 Ø4.8mm Screw.....	
2.10. Removing.....	24
2.10.1 Removing Nail.....	
2.11 OP. Distraction, Compression.....	25
2.11.1 Compression.....	

## 3. Instrument

3.1. TRAY A .....	26
3.2. TRAY B .....	27
3.3. TRAY C .....	28

## 4. Disinfection

4.1. Device Cleaning Conditions.....	29
4.1.1. Manual Cleaning/Disinfection.....	
4.1.2. Combination Manual / Automated Cleaning and Disinfection:.....	
4.1.3. Automated Cleaning and Disinfection.....	

## 5. Appendix

5.1. Nail Length.....	30
5.1. Nail Length.....	



## 1.1 Femoral Nail

### 1.1.1. Specifications

It is designed based on the Anatomic Femoral Nail design to treat femoral fractures and deformations. Unlike the others, there are two 90 ° holes in its proximal part. Proximal diameter is 13 mm. Neck angle is 130 ° and reaches 135 ° with 5 ° lateral offset. ZFN is available in various lengths from 260 mm to 440 mm (in 20 mm increments). Diameter size options are also in the form of Ø 9,10,11,12,13,14 mm. Right and left designs are available. Nails and all of its components are made of Ti 6AL4V ELI material.

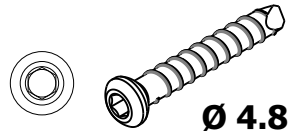

**ZFN Proximal/Distal Locking Screw**

REF. NO	SIZE
4292-4830	4.8x30
4292-4835	4.8x35
4292-4840	4.8x40
4292-4845	4.8x45
4292-4850	4.8x50
4292-4855	4.8x55
4292-4860	4.8x60
4292-4865	4.8x65
4292-4870	4.8x70
4292-4875	4.8x75
4292-4880	4.8x80
4292-4885	4.8x85
4292-4890	4.8x90

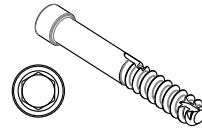

**ZFN Femoral Lag Screw**

REF. NO	SIZE
4612-6050	6.4x50
4612-6055	6.4x55
4612-6060	6.4x60
4612-6065	6.4x65
4612-6070	6.4x70
4612-6075	6.4x75
4612-6080	6.4x80
4612-6085	6.4x85
4612-6090	6.4x90
4612-6095	6.4x95
4612-6100	6.4x 100
4612-6105	6.4x 105
4612-6110	6.4x 110
4612-6115	6.4x 115
4612-6120	6.4x 120



**ZFN End Cap**

REF. NO	SIZE
4602-0000	0
4602-0005	5
4602-0010	10



REF. NO
4622-0000

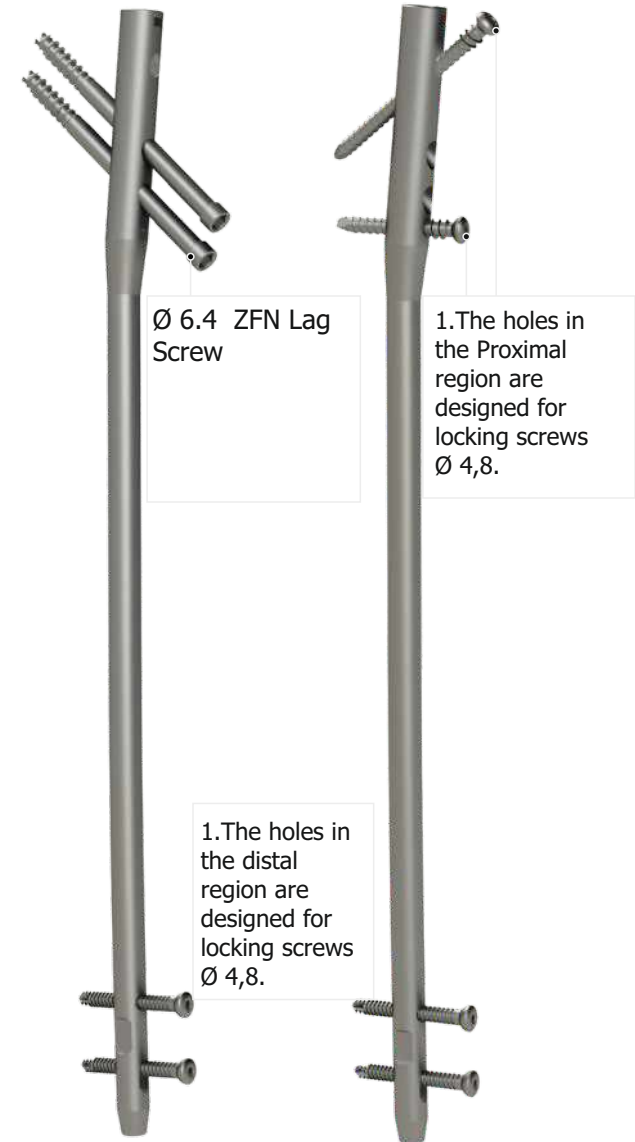



## 2.1 Fractures

### 2.1.1. Subtrochanteric Femur Fractures

Intramedullary nailing can be used for all subtrochanteric femur fractures that do not extend to the piriformis fossa or greater trochanter.

### 2.1.2. Femur Shaft Fractures

Statically Locked intramedullary nail is standard of care for femoral shaft fracture. Intramedullary Nailing has some advantages over plates and screws. These are a lower infection rate, less quadriceps scarring, early functional use, rapid fracture healing etc.

### 2.1.3. Femur Intertrochanteric Fractures

*Fixation may be required first before nail insert by fracture types*

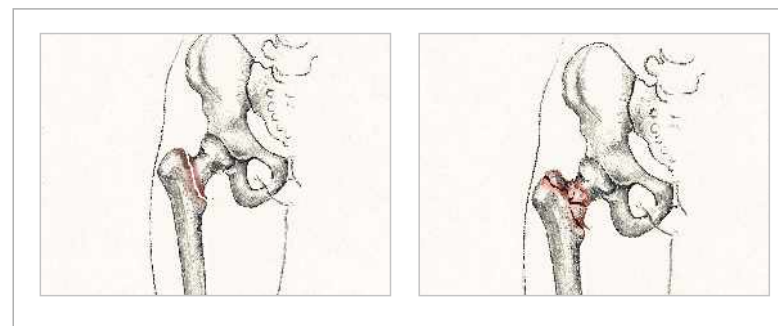
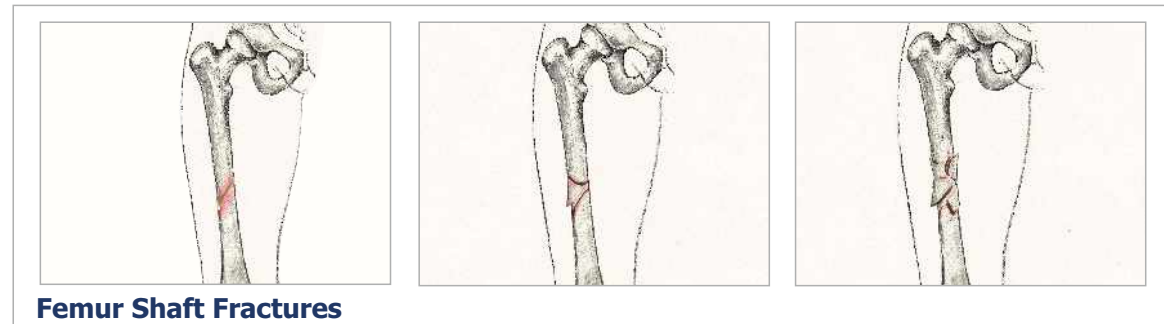
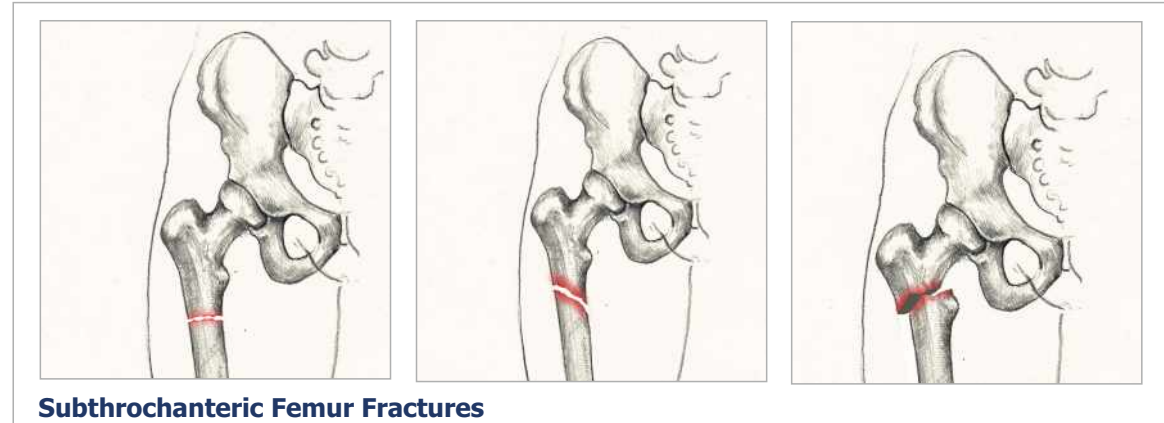



## 2.2 Preparation

### 2.2.1. Determining Nail Length

The nail length should be decided after fracture reduction. Alternatively, measurement can be taken on the undamaged leg. In addition, measurements can be taken on the flexible reamer.

(A2 Measurement tool)

Position it on the proximal femur and acquire a fluoroscopy view. Mark on skin

Move distal to the femur, Match the (A2 Measurement tool) with your marked proximal location. Take measurement and fluoroscopy images from the distal.

It is aligned to the narrowest part of the Medular Canal. Nail Diameter is determined by reading the table.

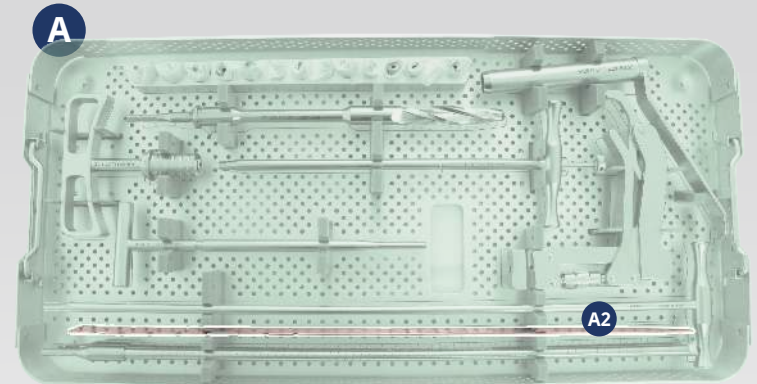
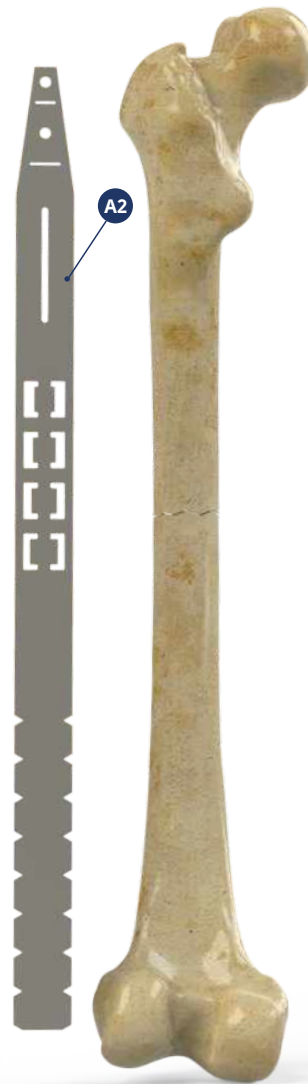



## 2.2 Preparation

### 2.2.2. Determine Entry Point

#### 2.2.2.1. Great Trochanter

The nail insertion point is at the tip of the greater trochanter. This represents a point 5 ° lateral to the femoral shaft axis measured from a point just below the lesser trochanter as the angle of the nail is between 5 ° and 7 °. (Fig.A)

Entry point for the nail is centered in the greater trochanter and in line with the medullary canal (Fig.B).

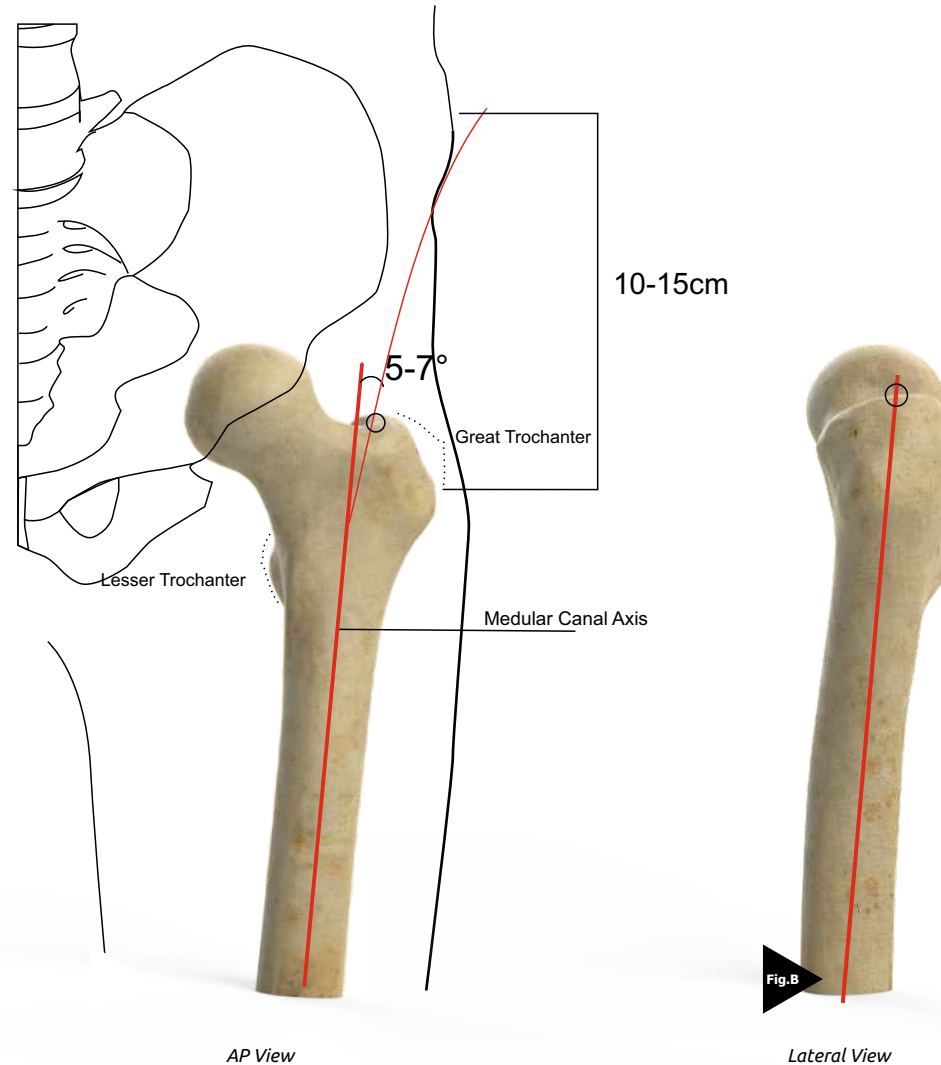



## 2.3 Medullary Canal

### 2.3.1. Entry opening

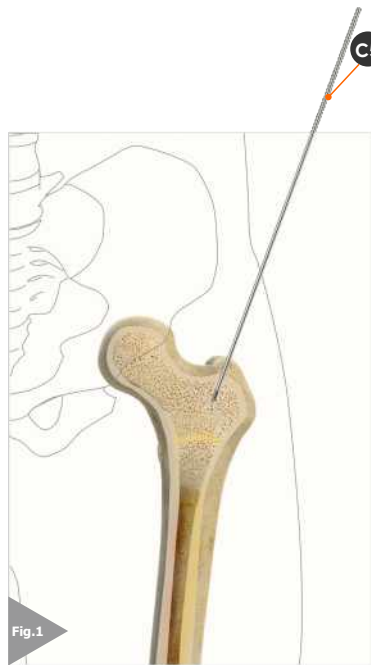

Insert (C5 Grooved Kirschner Wire) to the surgical motor and advance it through the entry point you specified. (Fig.1).

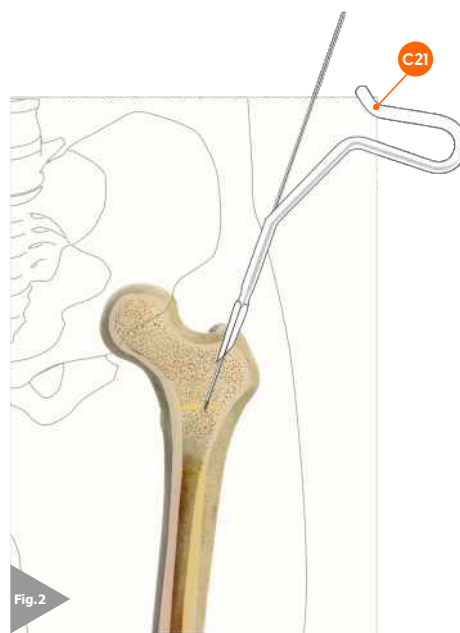

Run (C21 AWL) over (C5 Grooved Kirschner Wire). Open the input channel (Fig.2).

Remove (C21 AWL)

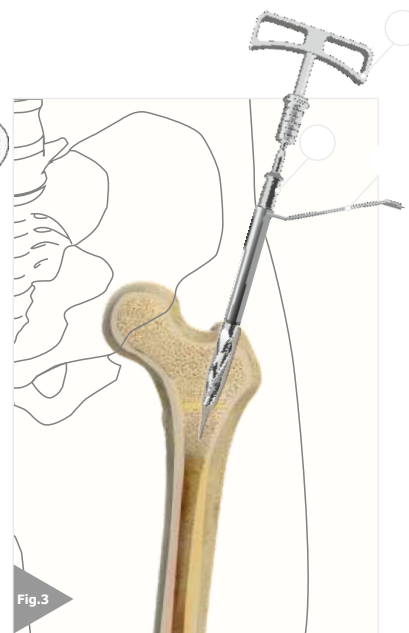

Combine (A6 Proximal Reamer) with (A5 Cannula T holder) Carve through the (C5 Grooved Kirschner Wire) and (A9 proximal Drill Guide). (Fig.3).

Remove (A6 Proximal Reamer) (A5 Cannula T holder), (C5 Grooved Kirschner Wire)





## 2.3 Medullary Canal

### 2.3.2.Reduce Fracture

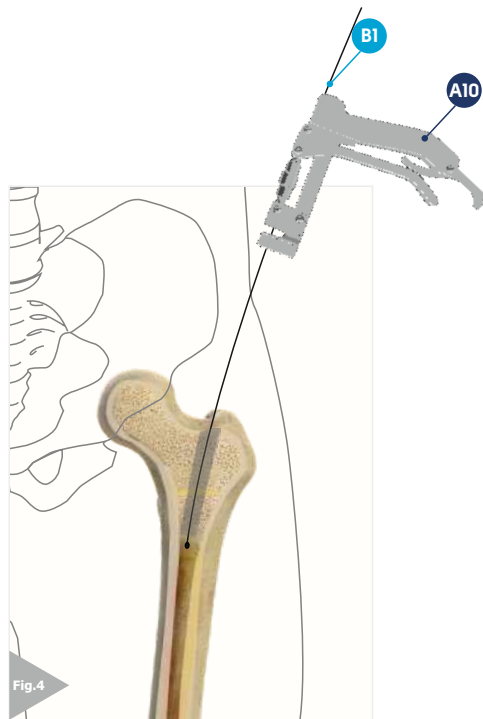

Combine (A10 Guide Wire holder) with (B1 Guide Wire) send through in the canal. (Fig4)

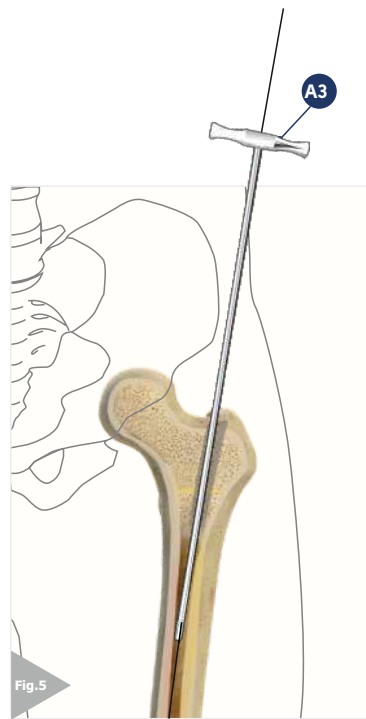

Advance the (A3 Anatomic Femoral T-Chisel) through the canal (Fig.5). After passing the fracture line, reduce fracture by following under viewing. (Fig.6-7)

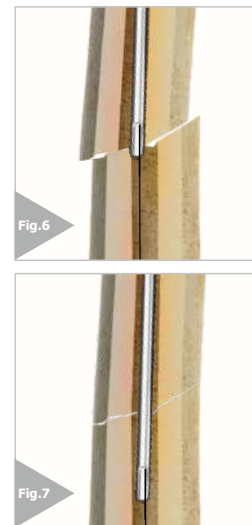

Remove (A3 Anatomic Femoral T-Chisel)

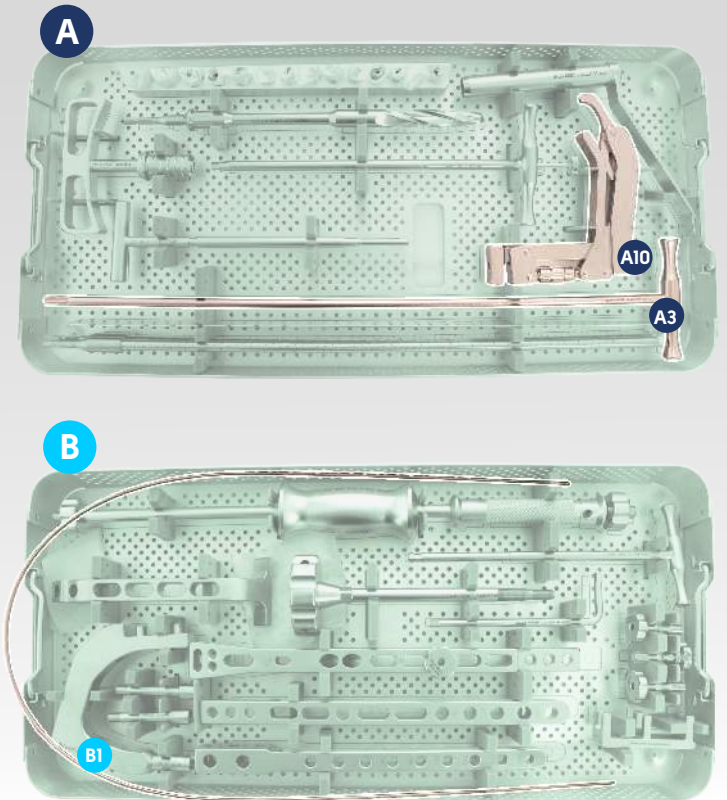



2.3 Medullary Canal  
2.3.3. Reaming Canal

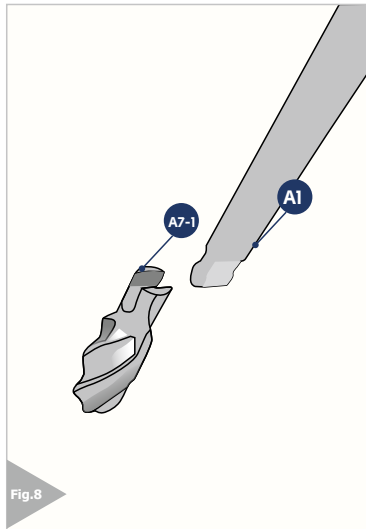

Combine (A1 Flexible Reamer) with (A7-1 Flexible Reamer Tip) (Fig.8).

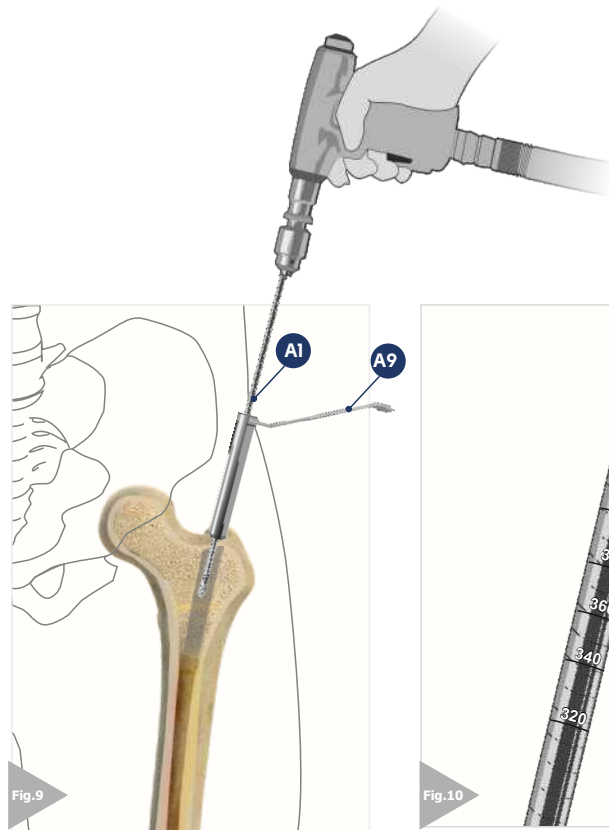

Insert to the surgical motor start to reaming trough (A9 Proximal Drill Guide) (Fig.9). Continue towards the oversized ends until you get the ideal width (A7Flexible Reamer Tip)

Remove (A9 Proximal Drill Guide)

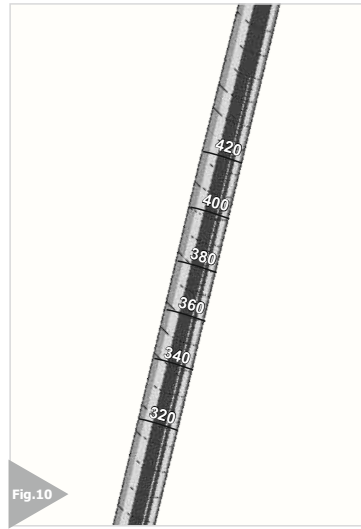

You can determine or verify nail length with table on the reamer (Fig.10)

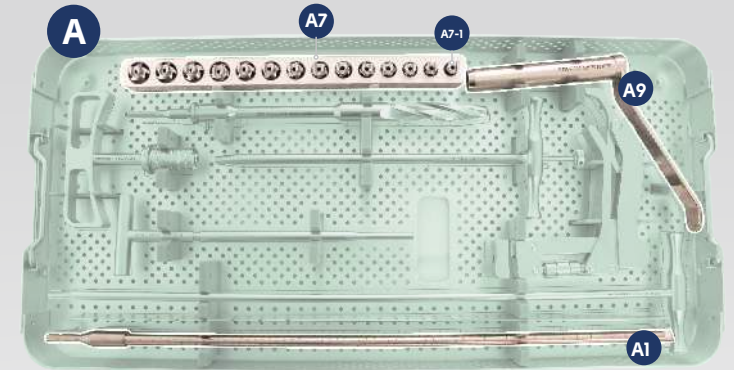



### 2.4 Nail

#### 2.4.1. Placement Of the Nail



Combine (B2 Handle) with (ZFN) Use (B6 T Screwdriver) with (B3 Bar Aiming Holder Screw) and pass from (B2 Handle) screw hole and complete fixing with Nail (Fig. 11. )

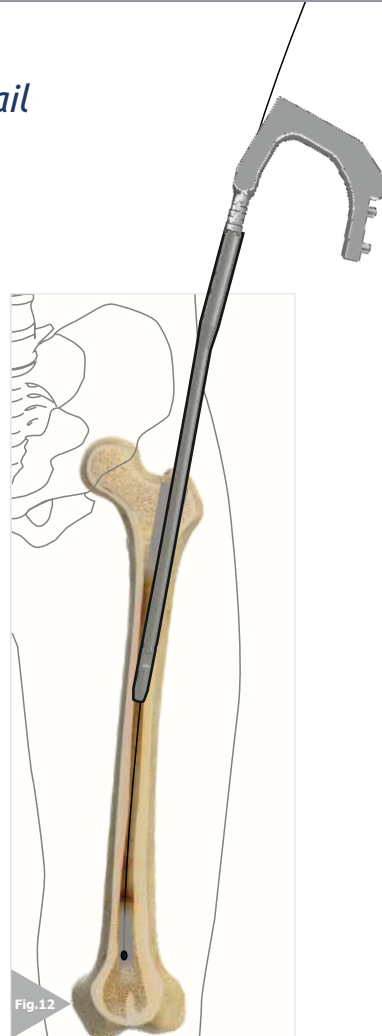

Pass this combination over (B1 Guiding Wire) advance through the channel (Fig. 12).

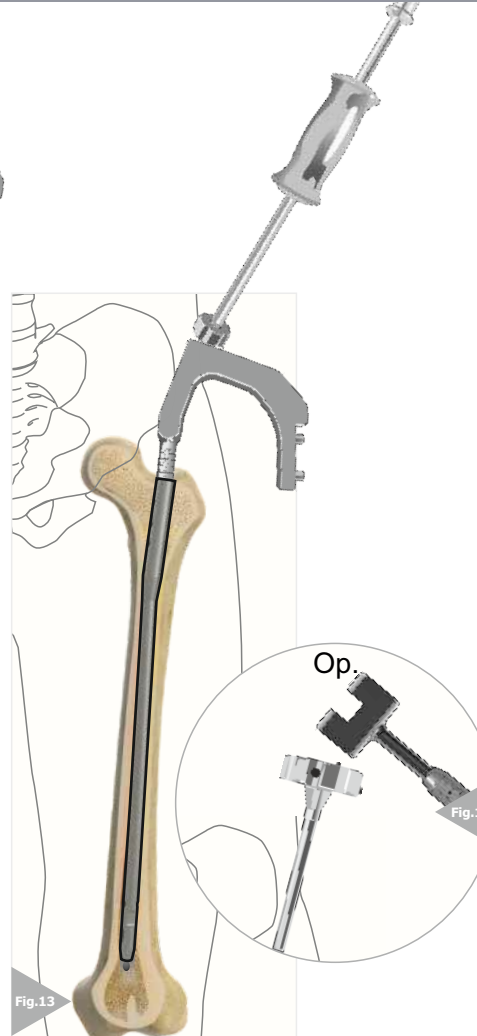

Assemble the (B5 Movable Hammer) with the (Holder B2). Tighten the (B5-1 Movable Hammer Shaft) screw. Fix it with the (B5-2 Movable Hammer) handle, insert the nail into the channel by moving back and forth in the nail direction (Fig. 13). If you want hammer use (B7 Hammer Tool) (Fig. 14)

Remove the (B5 Moving Hammer)

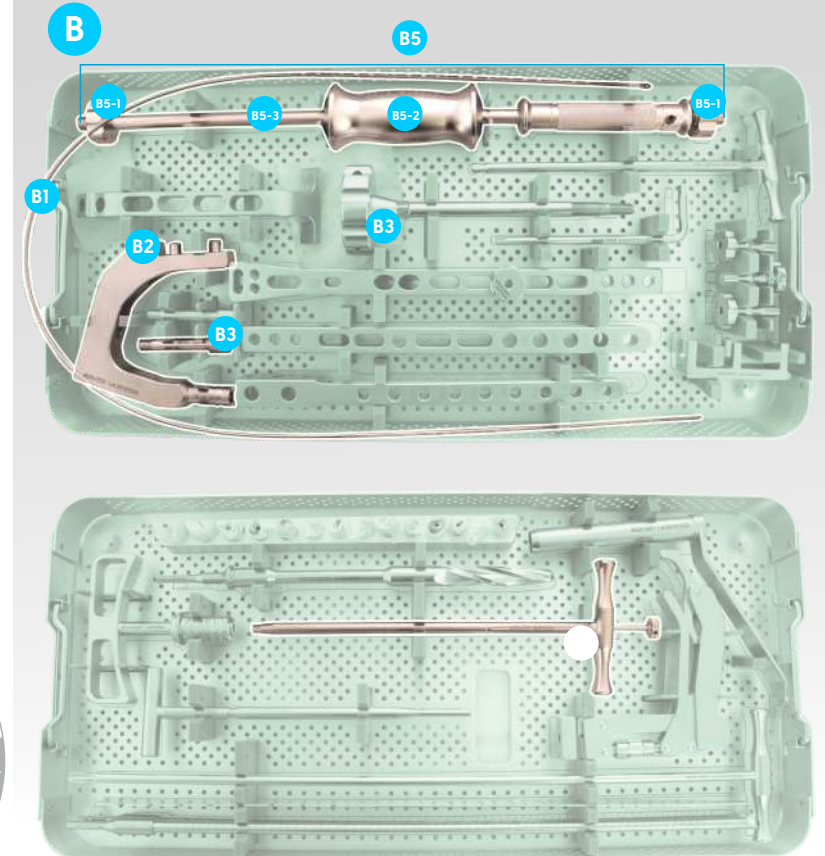



## 2.5 Locking

### 2.5.1. Proximal Locking

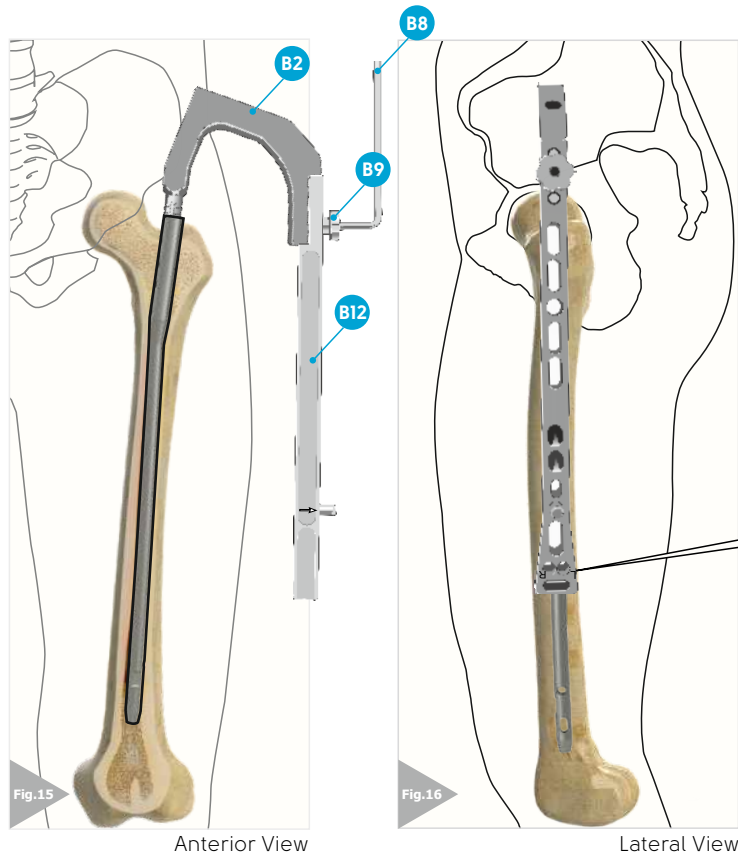

Combine *(B2 Holder)* and *(B12 Aiming Tool Right / Left)* from the joining zones. Insert *(B9 Proximal Guide Screw)* into the hole. Tighten and fix with *(B8 L key)*. (Fig.15-16).

Remove the *(B8 L Key)*

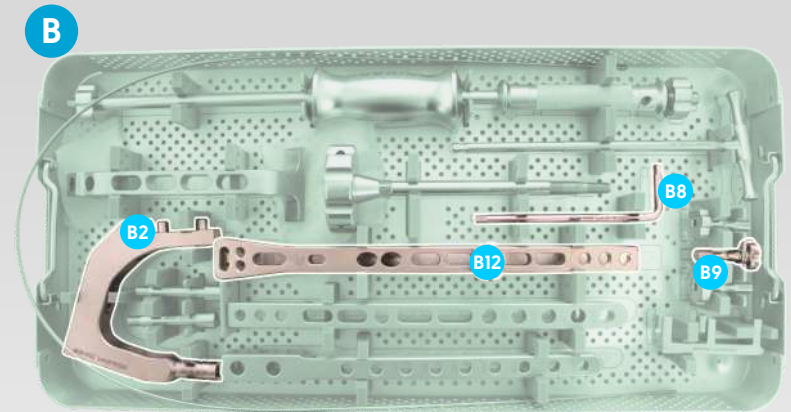



## 2.6 Proximal Screws

### 2.6.1. Screw location

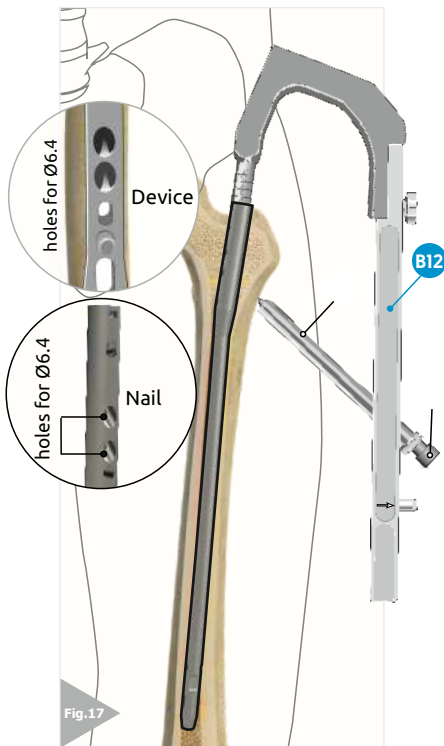

Attach (C9 Centering Tube) to (B12 Targeting Tool Right/ Left) inside holes. This is designed for Ø6.4 screws  
 Insert (C19 Point Marker) into (C9 Centering Tube) and locate the screw.  
 Remove (C19 Point Marker)  
 (Fig.17)

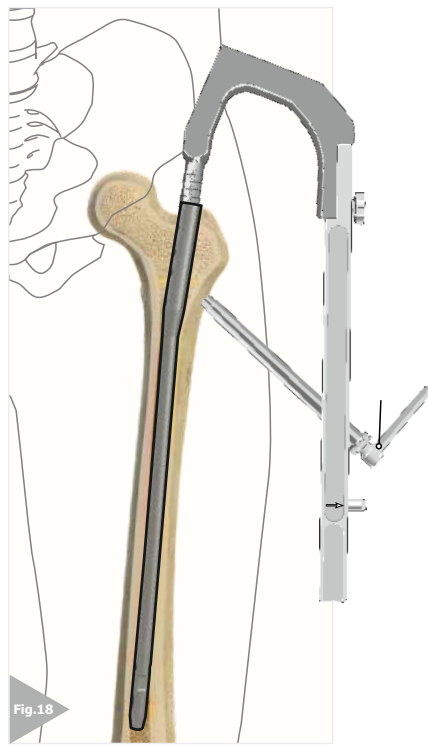

insert (C12 Kirschner Guide Ø2.5) instead (Fig.18).

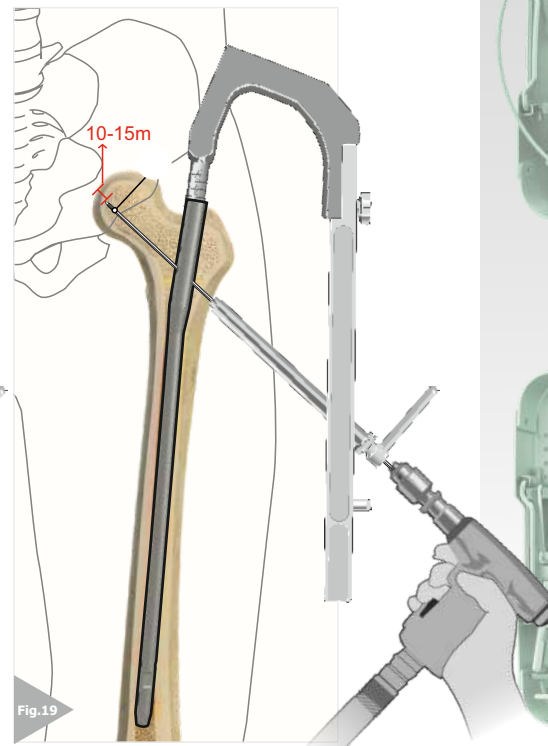

(C5 Grooved Kirschner Wire Ø2.5) insert surgical motor.  
 insert through (C12 Kirschner Guide Ø2.5) advance through the femoral head (Fig.24).  
 Follow the process in scopy (Fig.25).

Remove (C12 Kirschner Guide Ø2.5)

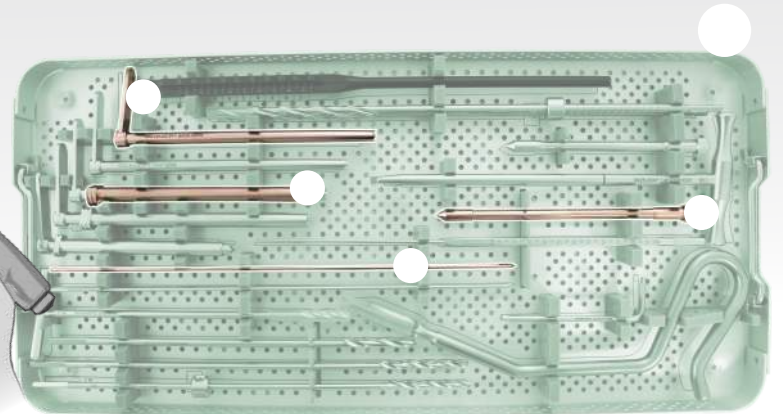
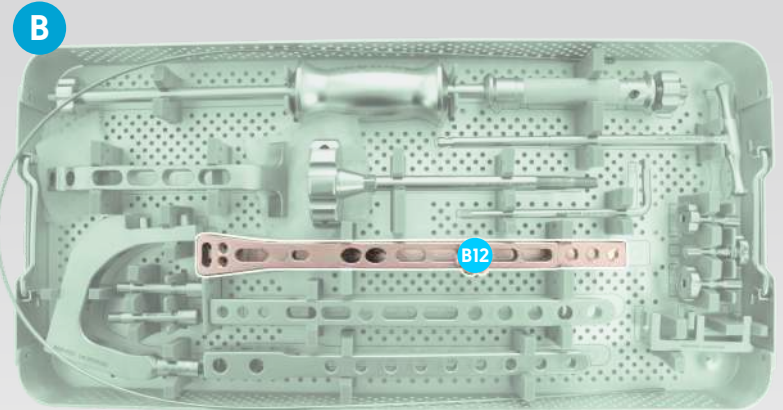



## 2.6 Proximal Screws

### 2.6.2. Determine Screw Length

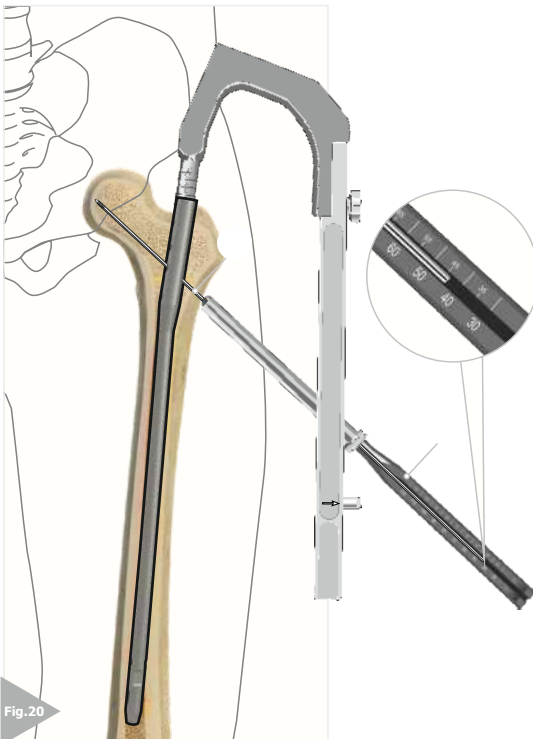

Pass (C13 Depth Guide) over (C5 Grooved Kirschner wire Ø2.5). Read the measurement and determine the screw length (Fig.20).

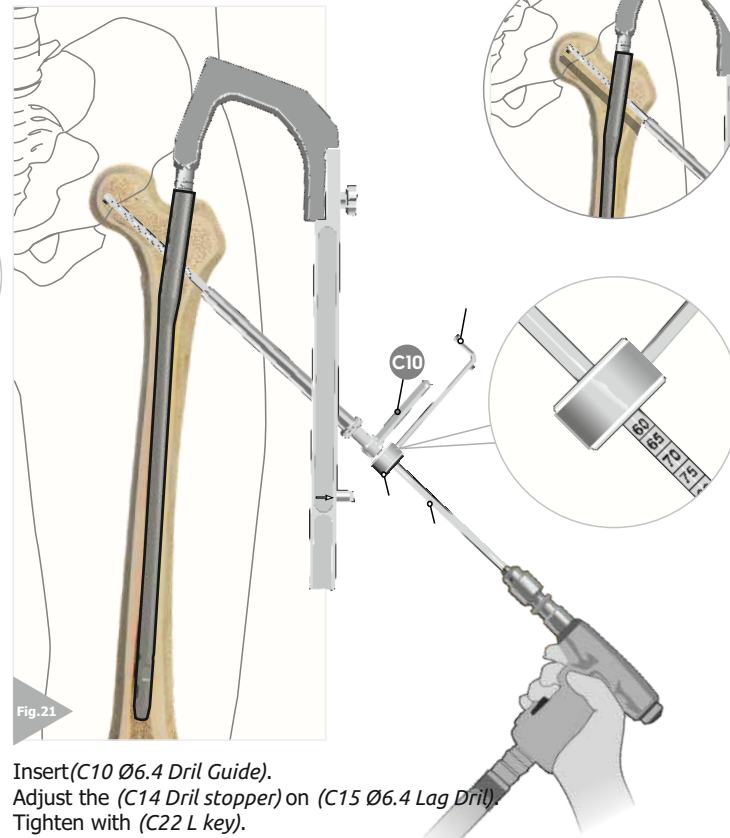

Insert (C10 Ø6.4 Drill Guide). Adjust the (C14 Drill stopper) on (C15 Ø6.4 Lag Drill). Tighten with (C22 L key). insert the (C15 Ø6.4 Lag Drill) to the surgical motor Complete the drilling process in (C10 Ø6.4 Drill Guide) (Fig.21)

Remove (C13 Depth Guide).  
Remove (C5 Grooved Kirschner Wire Ø2.5) with surgical Motor .

remove it after the process is completed

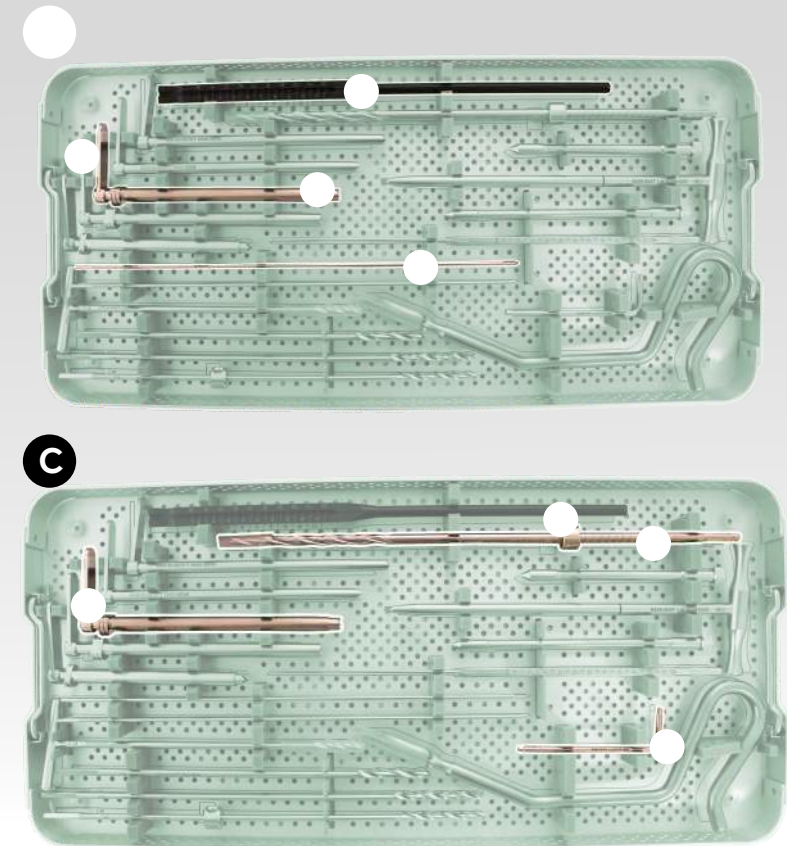

Pass (C13 Depth Guide)  
(Kirschner wire Ø2.5) and determine the screw length



## 2.6 Proximal Screws

### 2.6.4. Ø6.4mmLag Screw

Hold the Lag screw with (A8 T Lag screwdriver).  
 Insert the (A8-1 Lag screwdriver shaft)  
 Screw the lag screw (C9 Centering Tube)  
 through it.  
 Tighten the (A8 T Lag  
 screwdriver). (Fig.22)  
 Follow the procedure for the other  
 screw. (Fig.23)

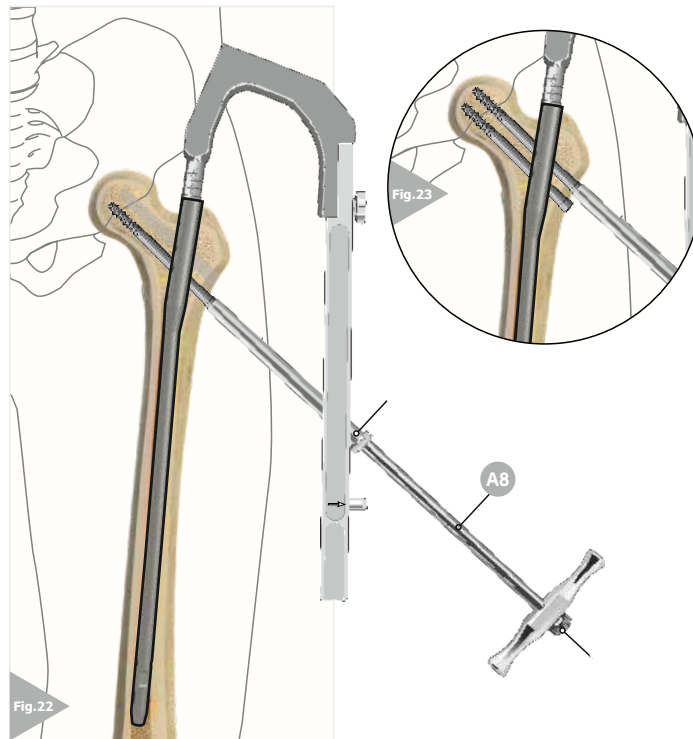

Remove (C9 Centering Tube).

REF. NO	LENGTH (mm)	REF. NO	LENGTH (mm)
4612-6050	50	4612-6085	85
4612-6055	55	4612-6090	90
4612-6060	60	4612-6095	95
4612-6065	65	4612-6100	100
4612-6070	70	4612-6105	105
4612-6075	75	4612-6110	110
4612-6080	80	4612-6115	115
		4612-6120	120

C

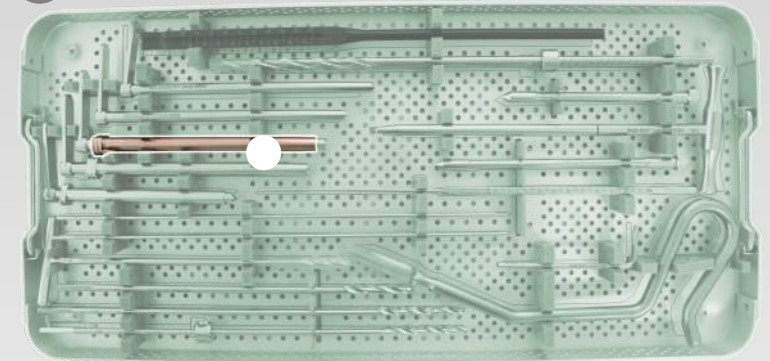

C

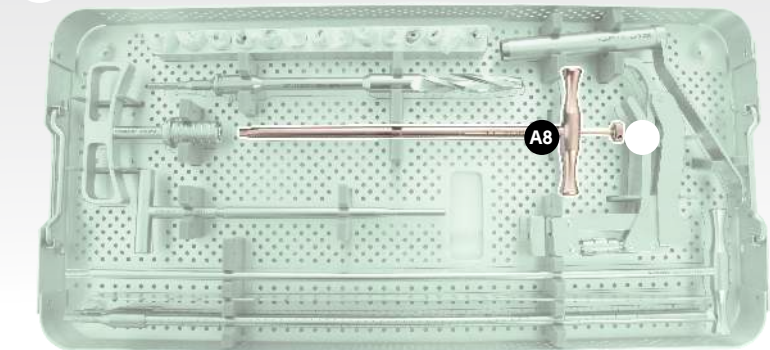



## 2.7 Locking 2

### 2.7.1. Distal Locking

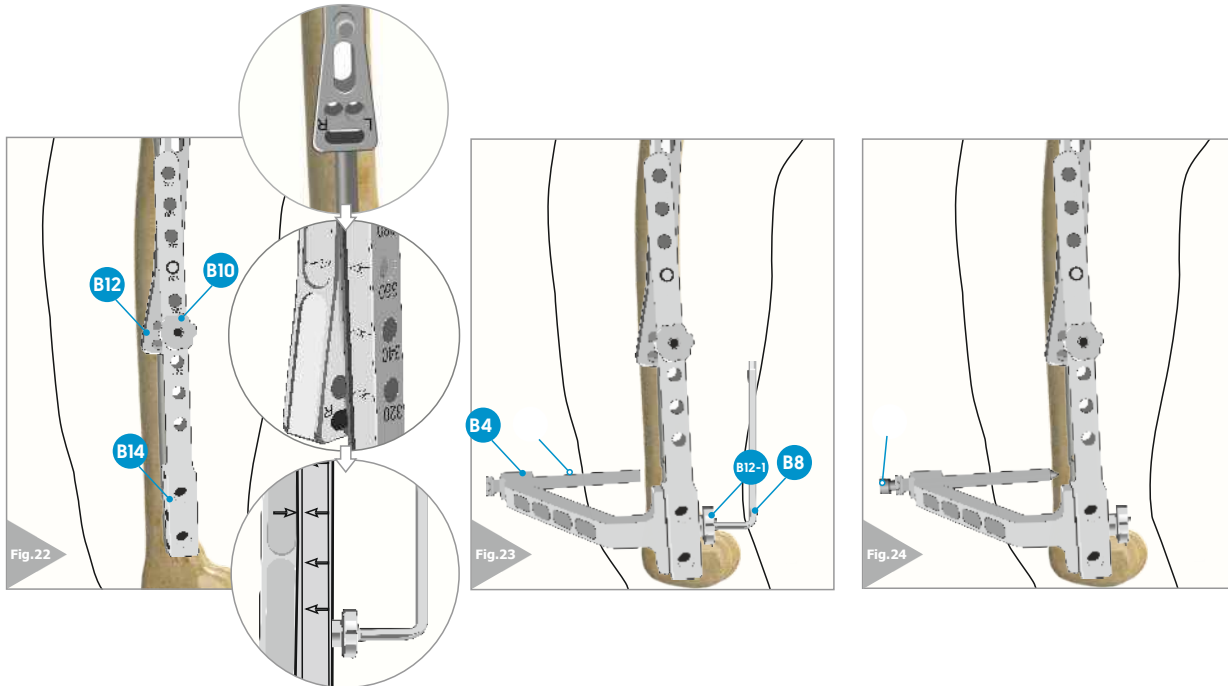

Combination of the targeting device is made according to the nail length. Use the length which is determined in the measurement steps.

Combine (B12 Aiming Device Right / Left) with (B14 Aiming Tool). Attached according to right or left and length of the nail. Install the (B9 Aiming Tool Screw) on the (B14 Aiming Tool). Tighten with (B8 L key) (Fig.22).

Attach the (B4 Distal Aiming Device) to the (B14 Aiming Tool). B12-1 Distal Guide) screw to fix it. Fix with (B8 L wrench).

In this case, the attachment of targeting devices is complete.

Insert the (C7 Centering Tube) into the fixing slot of the (B4 Distal Targeting) instrument. (Fig.23).

Place the (C17 Point Marker) inside. Make the marking. (Fig.24). Remove the (C17 Point Marker.) (Fig.44)

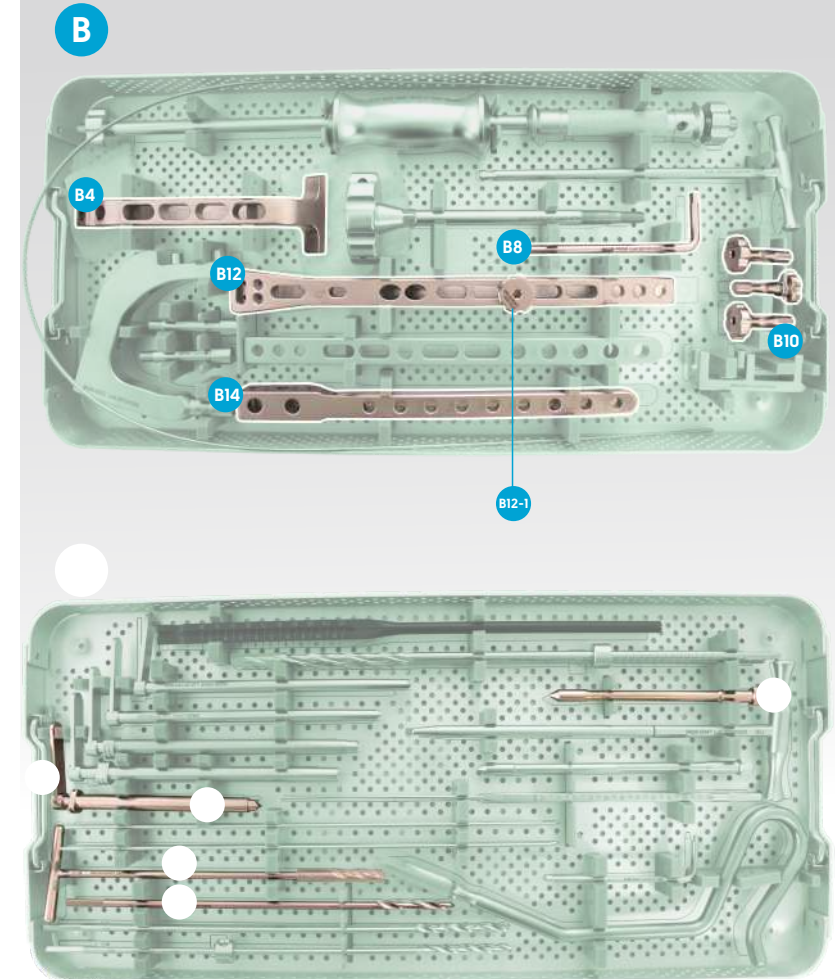



## 2.7 Locking 2

### 2.7.1. Distal Locking

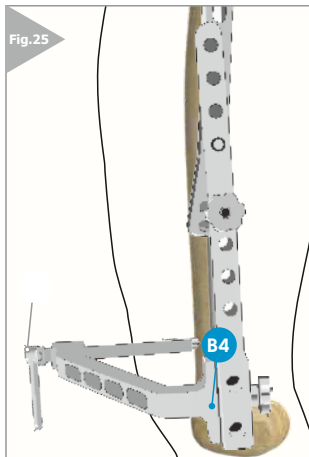

Fit (C6 Drill guide Ø5.2) to its place (Fig.25).

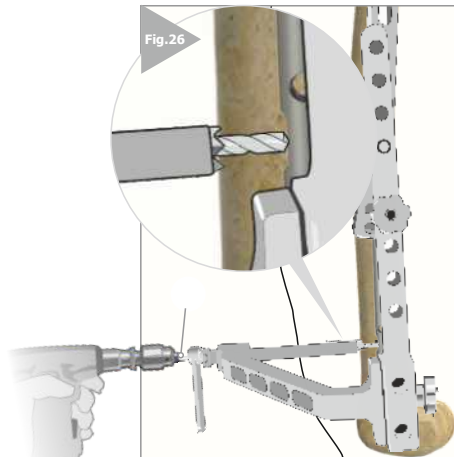

Drill with (C2 Drill Ø5.2).  
Remove (C6 Drill Guide Ø5.2) (Fig.26).

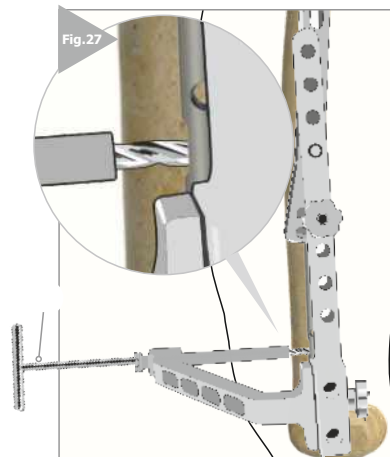

(C2 Drill Ø5.2) (C3 T Drill Ø5.2)

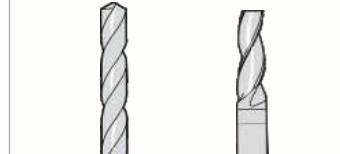

Make sure that the drilled area is fully opened with (C3 T Drill Ø5.2). The importance of this stage is that it enables the drilling of the area of the drill bit, which is close to the triangle, in a smooth form, and allows a more uniform fixation in the distal. (Fig.26-27).  
Remove (C3 T Drill Ø5.2) and (C6 Drill Guide Ø5.2).

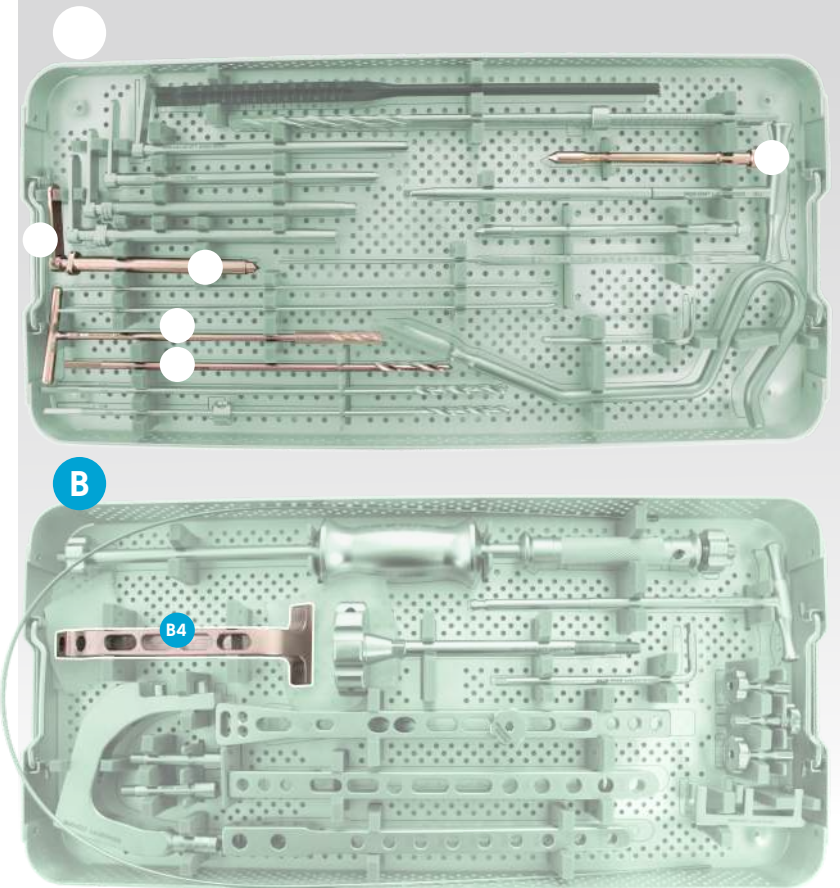



## 2.7 Locking 2

### 2.7.1. Distal Locking

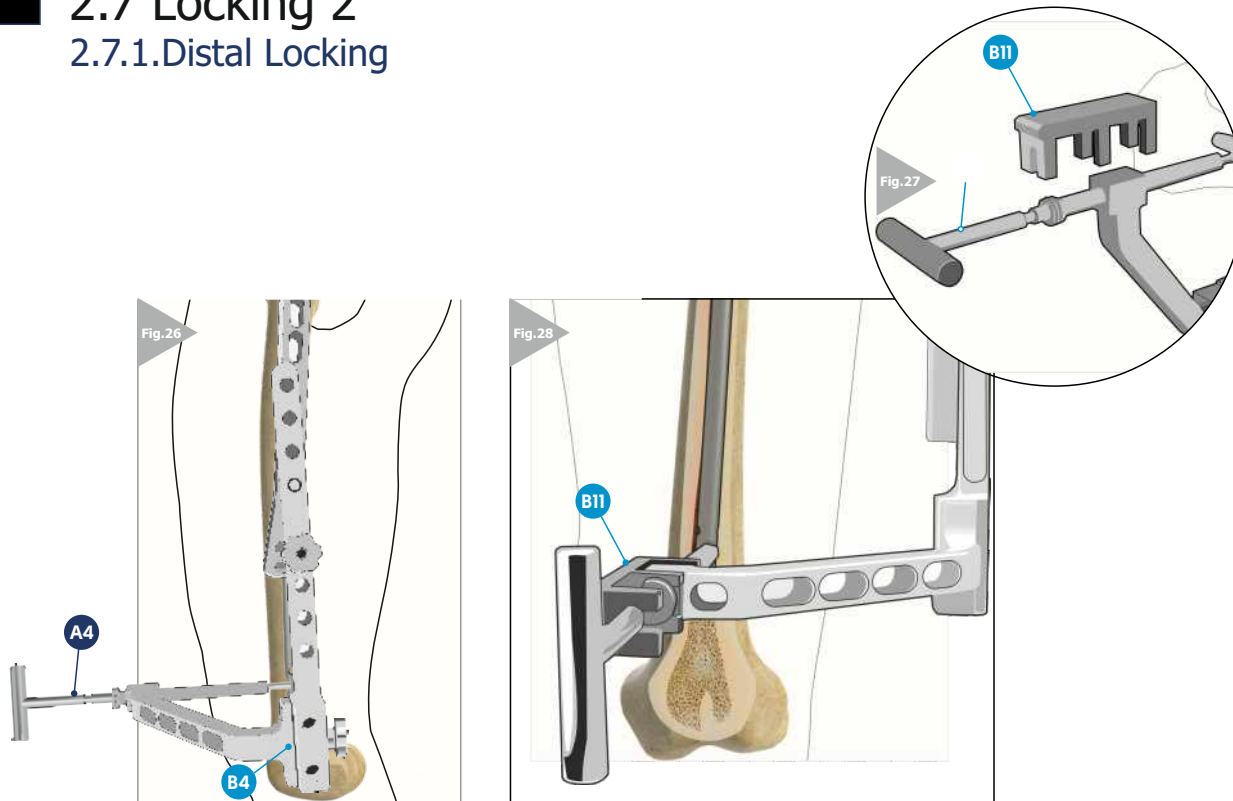

Attach (A4 T Distal Locking) to (B4 Distal Aiming Device) (Fig.26).  
Assemble (B11 E Distal Locking Screw) from the area suitable for (A4 T Distal Locking) and ensure the control. (Fig.27)  
In this way, distal locking will be completed. (Fig.28) Distal screwing can be started.

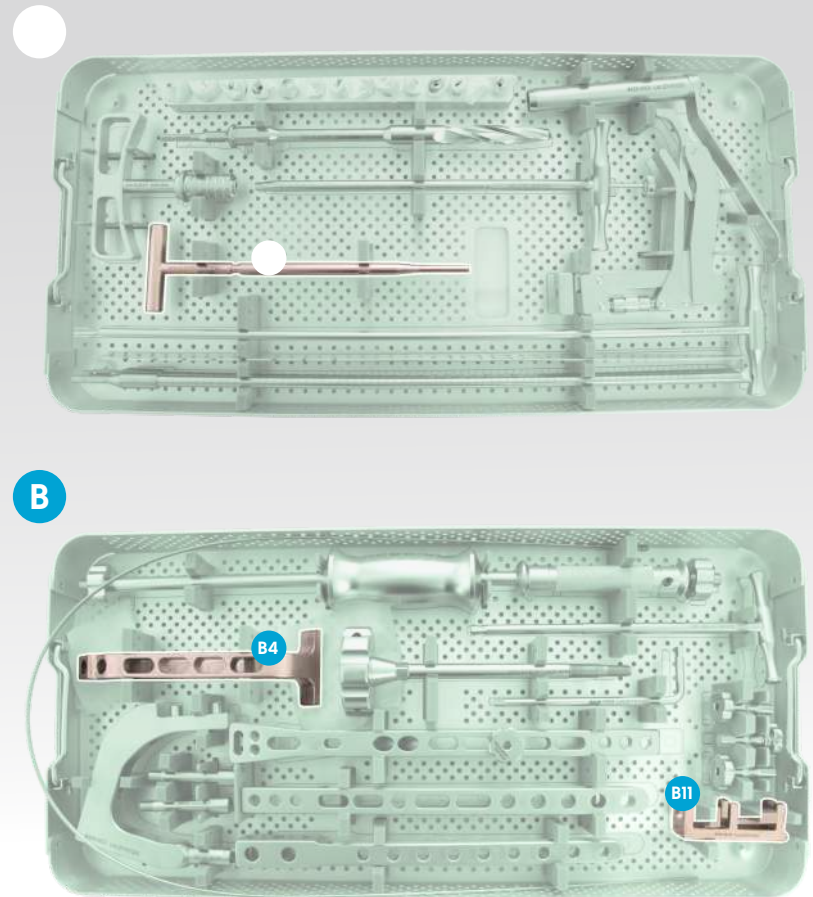



## 2.8 Distal ScREW

### 2.8.1. Drilling

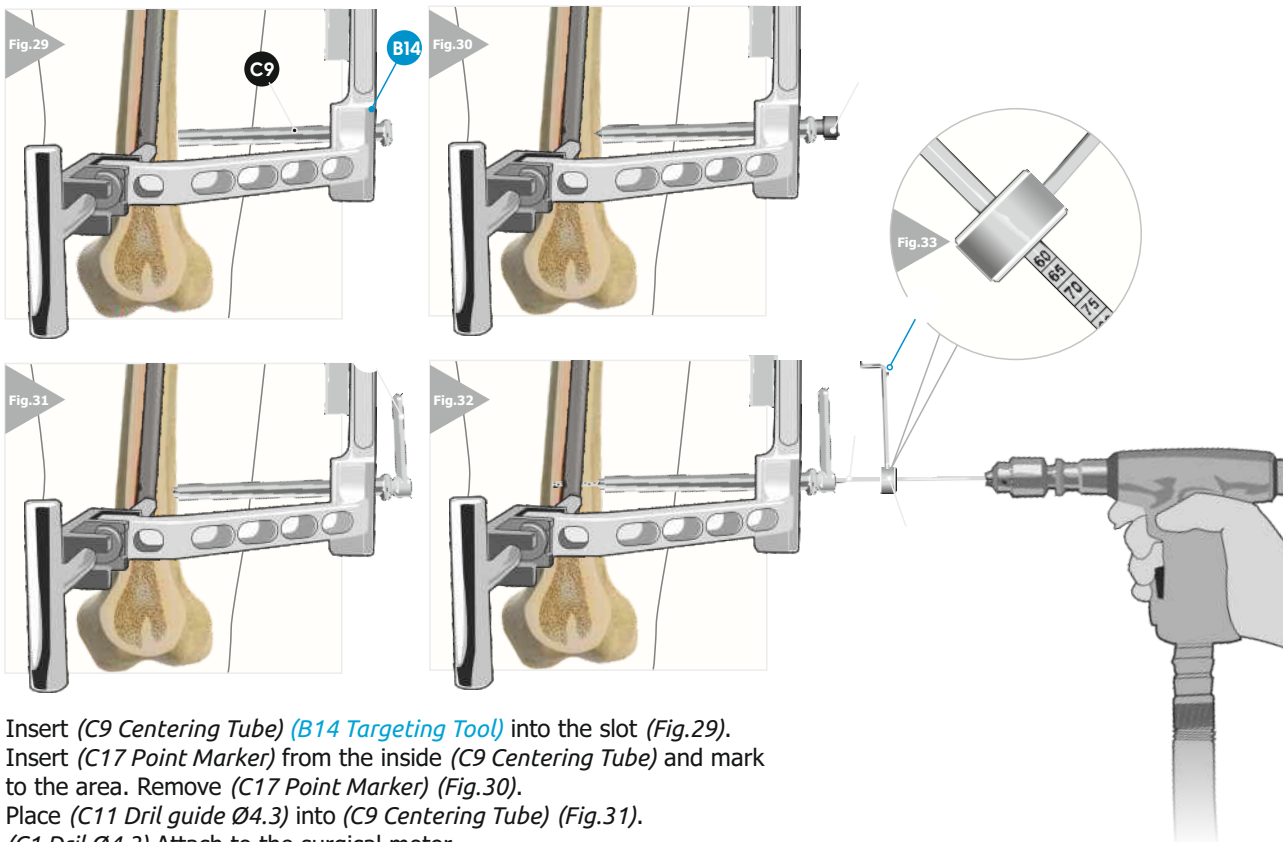

Insert (C9 Centering Tube) (B14 Targeting Tool) into the slot (Fig.29).

Insert (C17 Point Marker) from the inside (C9 Centering Tube) and mark to the area. Remove (C17 Point Marker) (Fig.30).

Place (C11 Drill guide Ø4.3) into (C9 Centering Tube) (Fig.31).

(C1 Drill Ø4.3) Attach to the surgical motor .

Drill up to the second cortex (Fig.32) Fix the (C23 Drill Stopper) you have adjusted with (C22 L Allen) (Fig.33)

Complete the drilling process.

Remove (C11 Drill guide Ø4.3).

C

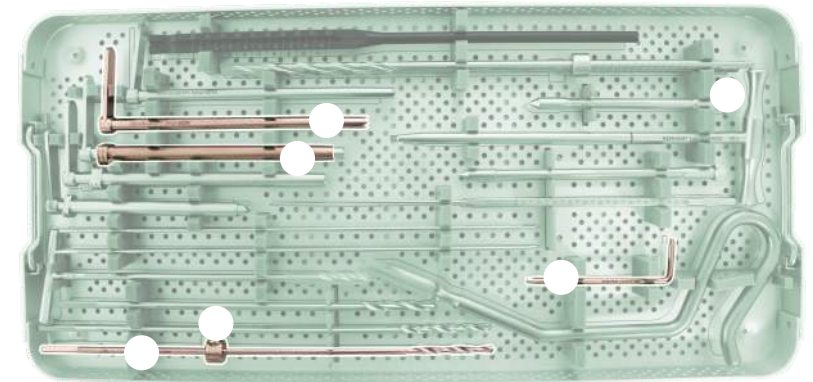

B

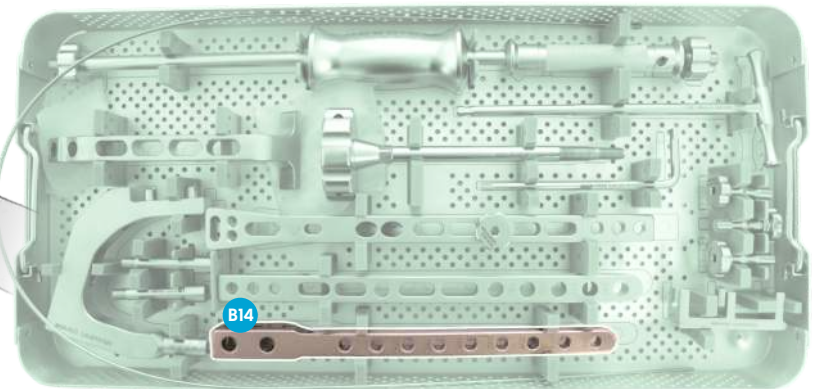



## 2.8 Distal Screw

### 2.8.2. Determine Screw Length & Ø4.8mm Screw

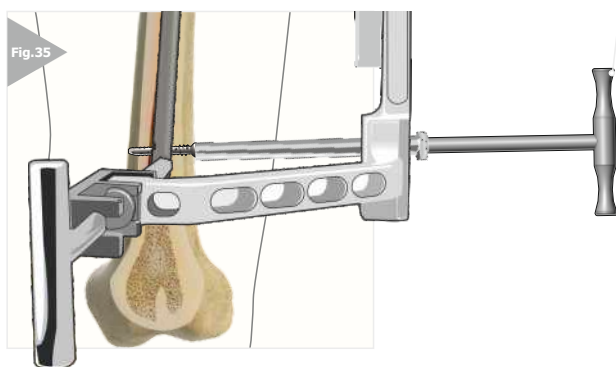
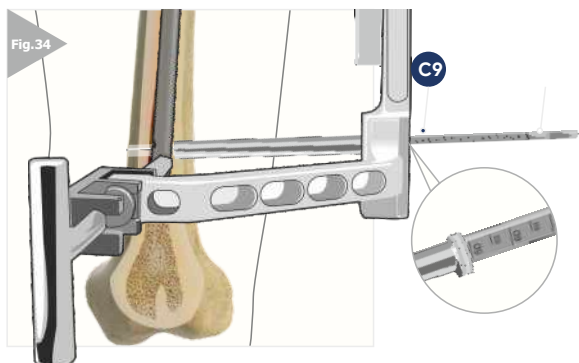

In the previous stage the drill guide was removed  
Place (C20 Depth Guide) into (C9 Centering Tube). Determine the Screw Length. (Fig.34). Remove the (C20 Depth Guide).  
Send the Ø4.8 screw (C9 Centering Tube) you determined the length with (C18 T Screwdriver) (Fig.35).

C

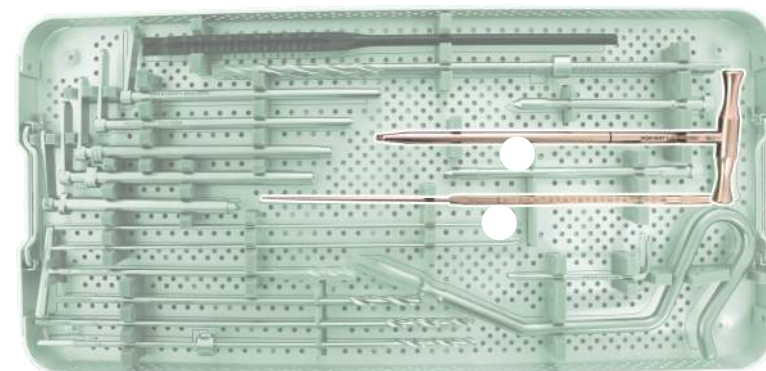

Proximal/Distal Locking Screw For ZFN  
(Ø 4.8 mm)



REF. NO	LENGTH (mm)
4292-4830	30
4292-4835	35
4292-4840	40
4292-4845	45
4292-4850	50
4292-4855	55
4292-4860	60
4292-4865	65
4292-4870	70
4292-4875	75
4292-4880	80
4292-4885	85
4292-4890	90



## 2.9 Finishing

### 2.9.1. Removing Targeting Device

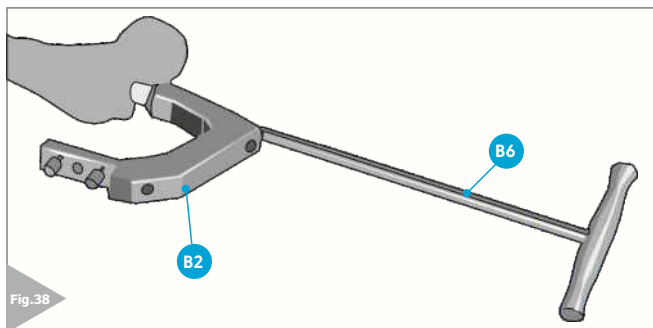
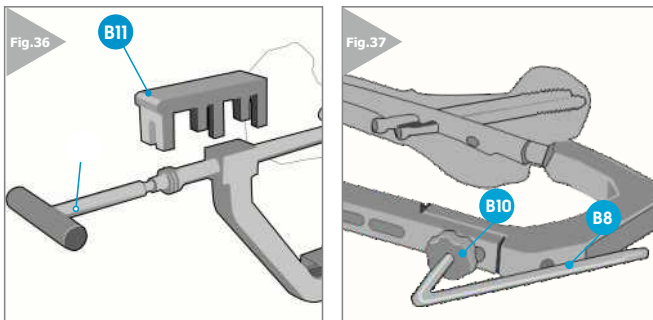

All screws were attached and fixed on the nail in previous steps. The targeting and fixing parts are detachable. A reverse process will be done. *(B11 E Distal Locking Piece)* is removed. Then *(A4 T Distal Locking)* is removed. *(C7 Centering Tube)* can be removed (Fig.36).

*(B10 Proximal Guide Screw)* is loosened with *(B8 L key)* (Fig.37). Some of the targeting pieces can be removed as a whole. Later, these parts can be removed.

The remaining *(B2 Holder)* is loosened with *(B6 T Screwdriver)* and *(B3 Bar Targeting Holder Screw)* released and removed (Fig.38)

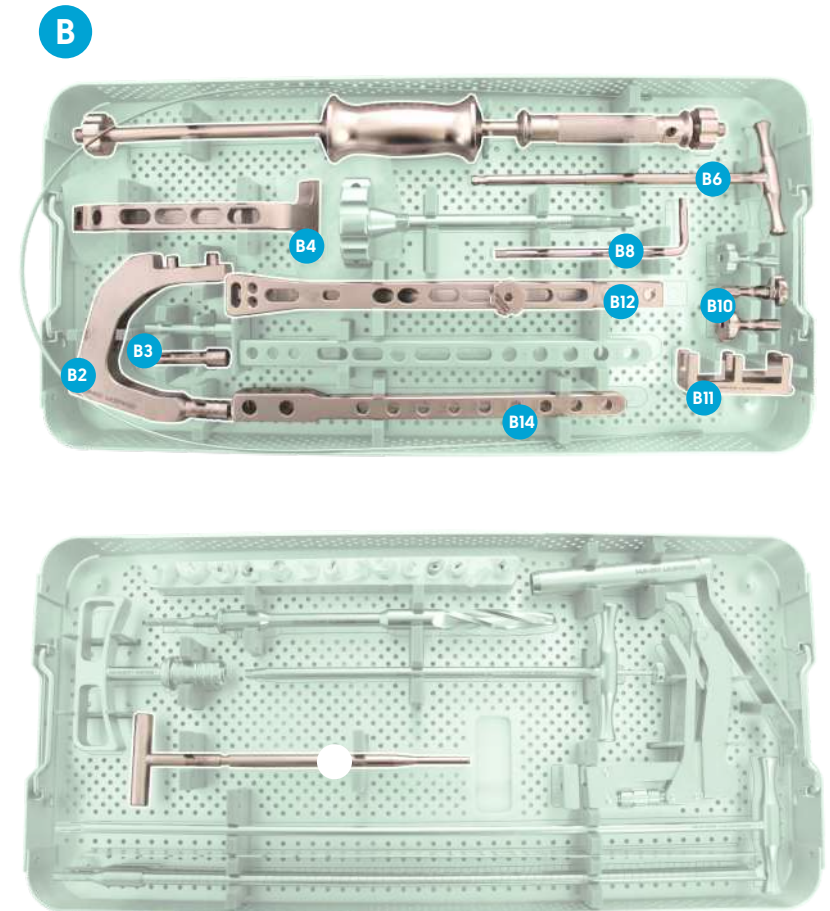



## 2.9 Finishing

### 2.9.2. End Cap

It is attached to its place with the appropriate size End Cap (*A8 T lag Screwdriver*) (*Fig.39*) and the process is completed. (*Fig.40*)

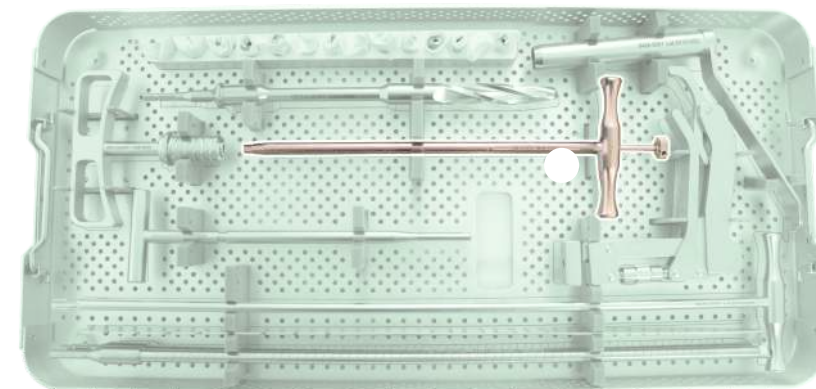
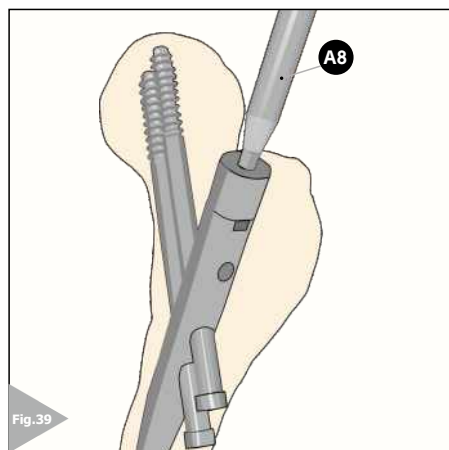

#### ZFN End Cap



REF. NO	LENGTH (mm)
4602-0000	0
4602-0005	5
4602-0010	10



## 2.10 Removing

### 2.10.1. Removing nail

In order for the nail to be removed, screws must be removed. End cap screw removed with (A8 T Lag Screwdriver) and then (Fig.41).

(B7 Driver) is attached to the end cap slot proximal to the nail. (Fig.79)  
It is attached to the (B7 Impact) part with (B5 Movable Hammer) (B5-1 Movable Hammer Shaft Screw). (Fig.42).

In this way All the screws on can be removed position.  
Proximal Screws are removed with (A8 T Lag Screwdriver).  
Distal screws are removed with (C18 T Screwdriver Ø3.5) (Fig.42).

The nail can be removed by holding it from the (B5-2 Movable Hammer) part by movements in the direction in the image. (Fig.43)

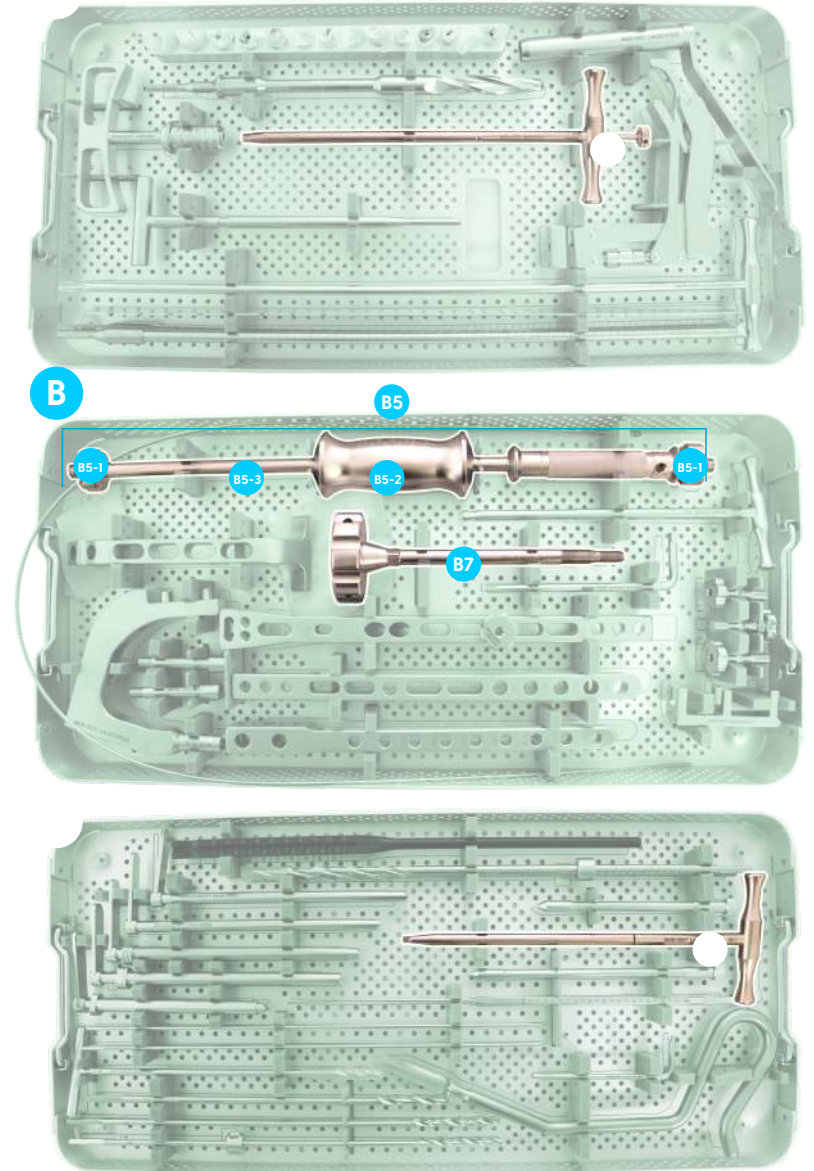
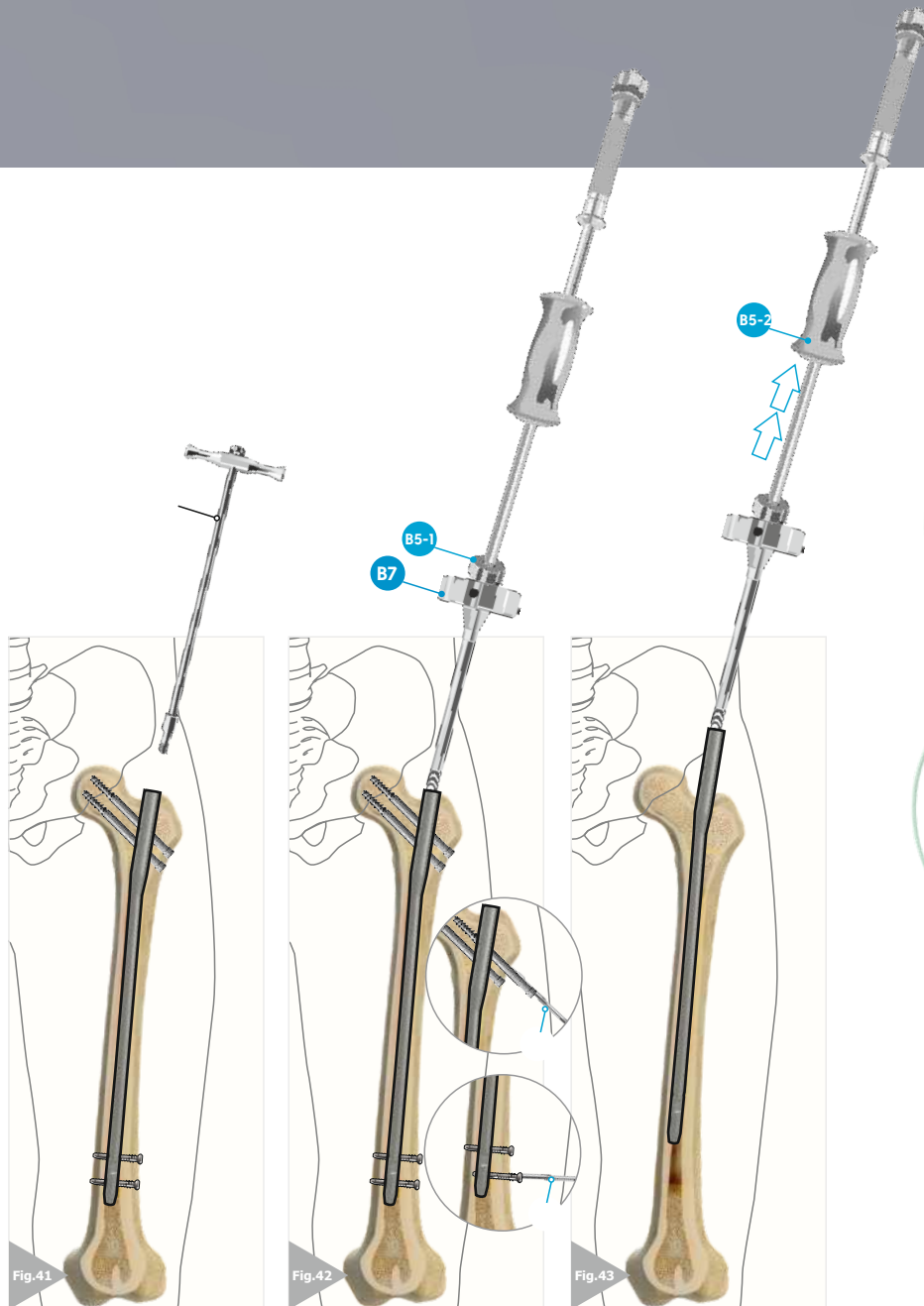



## 2.11 OP. Distraction, Compression

### 2.11.1. Compression

If necessary, before the distal screws are sent for compression (when the distal is in free position), after the proximal screws are attached, some compression can be obtained by connecting to *(B2 Holder) (B5 Movable Hammer)* (Fig.41). After the compression the distal screws are sent.

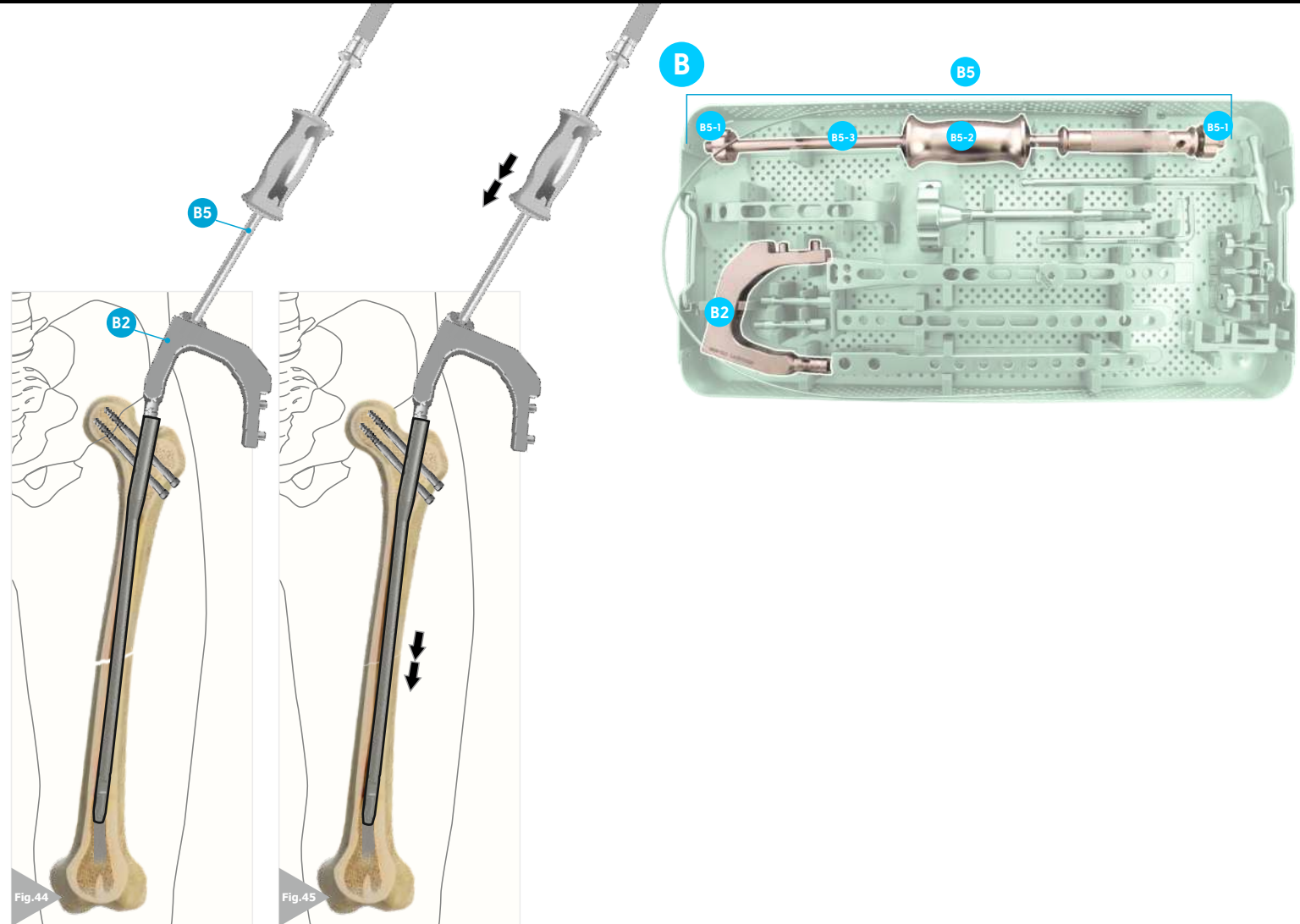

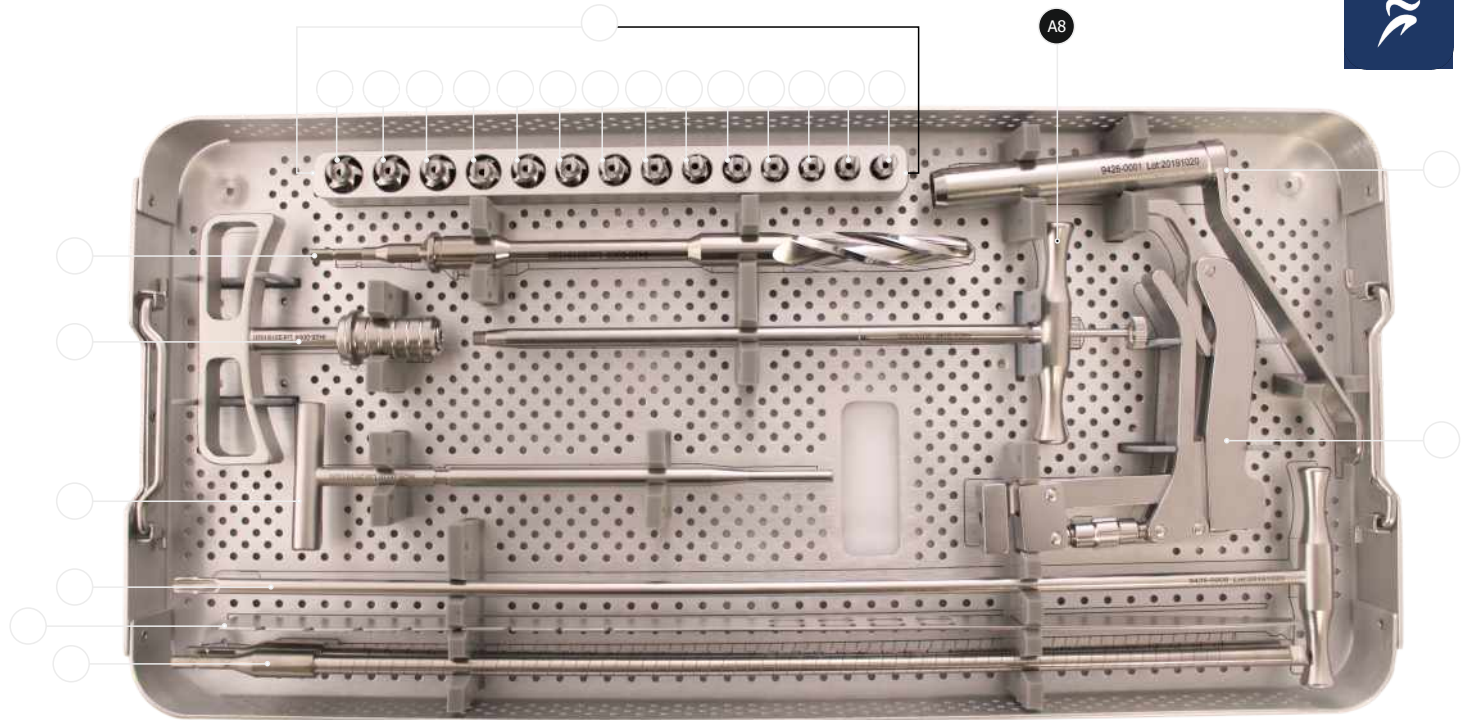

<b>A1</b>	Flexible Reamer Ø8x460mm	9426-0007
<b>A2</b>	Measurement Tool	9426-0061
	Anatomical Femoral T Chisel	9426-0005
	T Distal Locking	9426-0038
	Cannulated T Handle	9426-0004
	Proximal Reamer Ø14	9426-0003
	Flexible Reamer Tips	
	T Lag Screw SW5	9426-0048
	Proximal Drill Guide	9426-0001
	Handle	9413-0002

<b>A7-1</b>	Flexible Reamer Tip Ø8.5mm	9426-0085	<b>A7-8</b>	Flexible Reamer Tip Ø12mm	9426-0120
<b>A7-2</b>	Flexible Reamer Tip Ø9mm	9426-0090	<b>A7-9</b>	Flexible Reamer Tip Ø12.5mm	9426-0125
<b>A7-3</b>	Flexible Reamer Tip Ø9.5mm	9426-0095	<b>A7-10</b>	Flexible Reamer Tip Ø13mm	9426-0130
<b>A7-4</b>	Flexible Reamer Tip Ø10mm	9426-0100	<b>A7-11</b>	Flexible Reamer Tip Ø13.5mm	9426-0135
<b>A7-5</b>	Flexible Reamer Tip Ø10.5mm	9426-0105	<b>A7-12</b>	Flexible Reamer Tip Ø14mm	9426-0140
<b>A7-6</b>	Flexible Reamer Tip Ø11mm	9426-0110	<b>A7-13</b>	Flexible Reamer Tip Ø14.5mm	9426-0145
<b>A7-7</b>	Flexible Reamer Tip Ø11.5mm	9426-0115	<b>A7-14</b>	Flexible Reamer Tip Ø15mm	9426-0150



## B

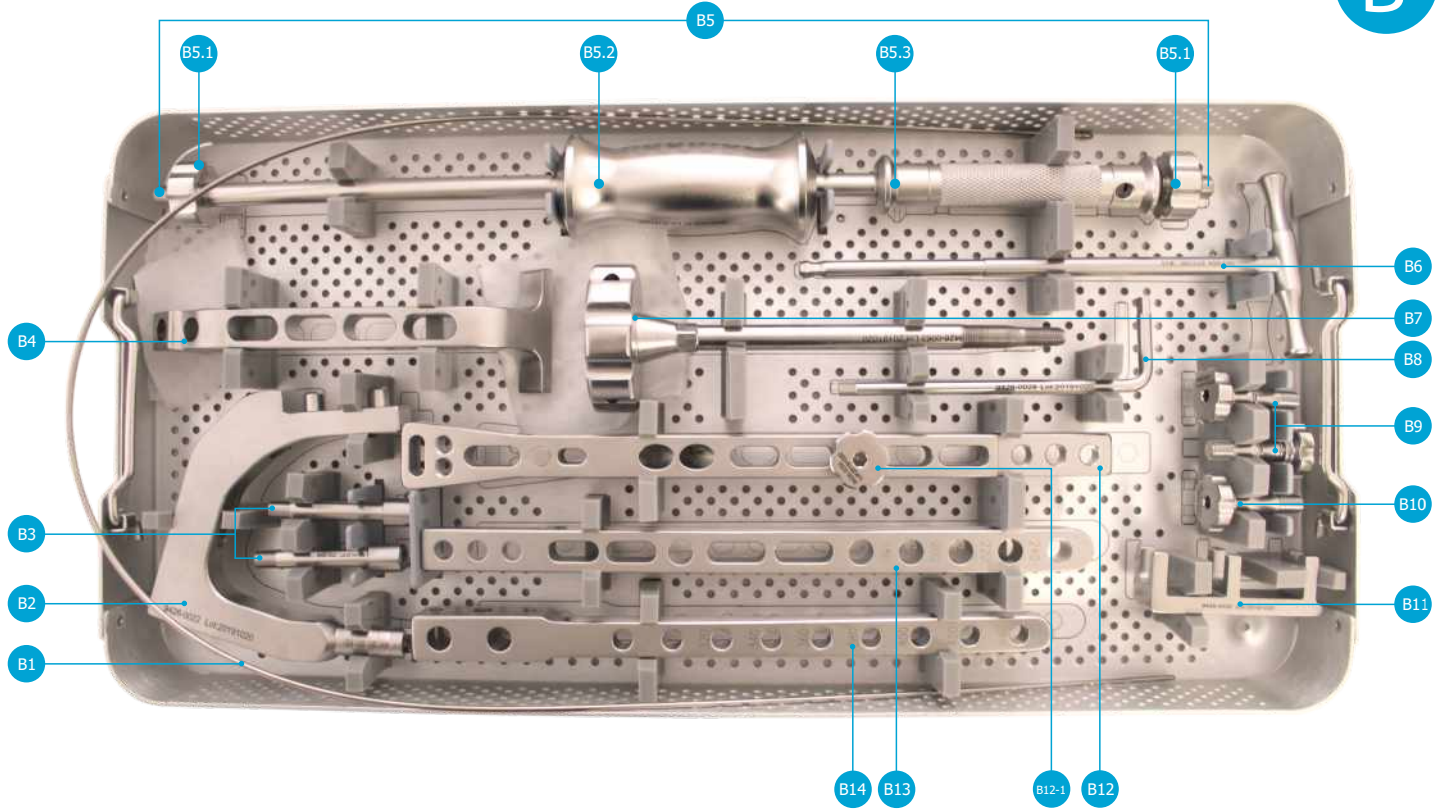

B1	Guide Wire Ø2.5/Ø3.3/1000mm With Knob	9426-0006
B2	Bar Targeting Device	9426-0022
B3	Bar Targeting Device Screw M8x1/SW6.5	9426-0023
B4	Distal Targeting Device	9426-0031
B5	Movable Hammer	
B6	T Screw SW Ø6.5	9426-0024
B7	Hammer Tool	9426-0063
B8	L Wrench SW 5	9426-0028
B9	Targeting Device Screw Short	9426-0027
B10	Proximal Guide Screw	9413-0060
B11	E Distal Locking Device	9426-0039
B12	Targeting Device Right/Left	9426-0026
B12-1	Distal Guide Screw	9413-0058
B13	Targeting Device(Short ZFN)	9413-0032
B14	Targeting Device	9413-0029

B5-1	Hareketli Çekiç Mili Vidası	9426-0025.3
B5-2	Hareketli Çekiç M10X1	9426-0025.1
B5-3	Hareketli Çekiç Mili	9426-0005.2

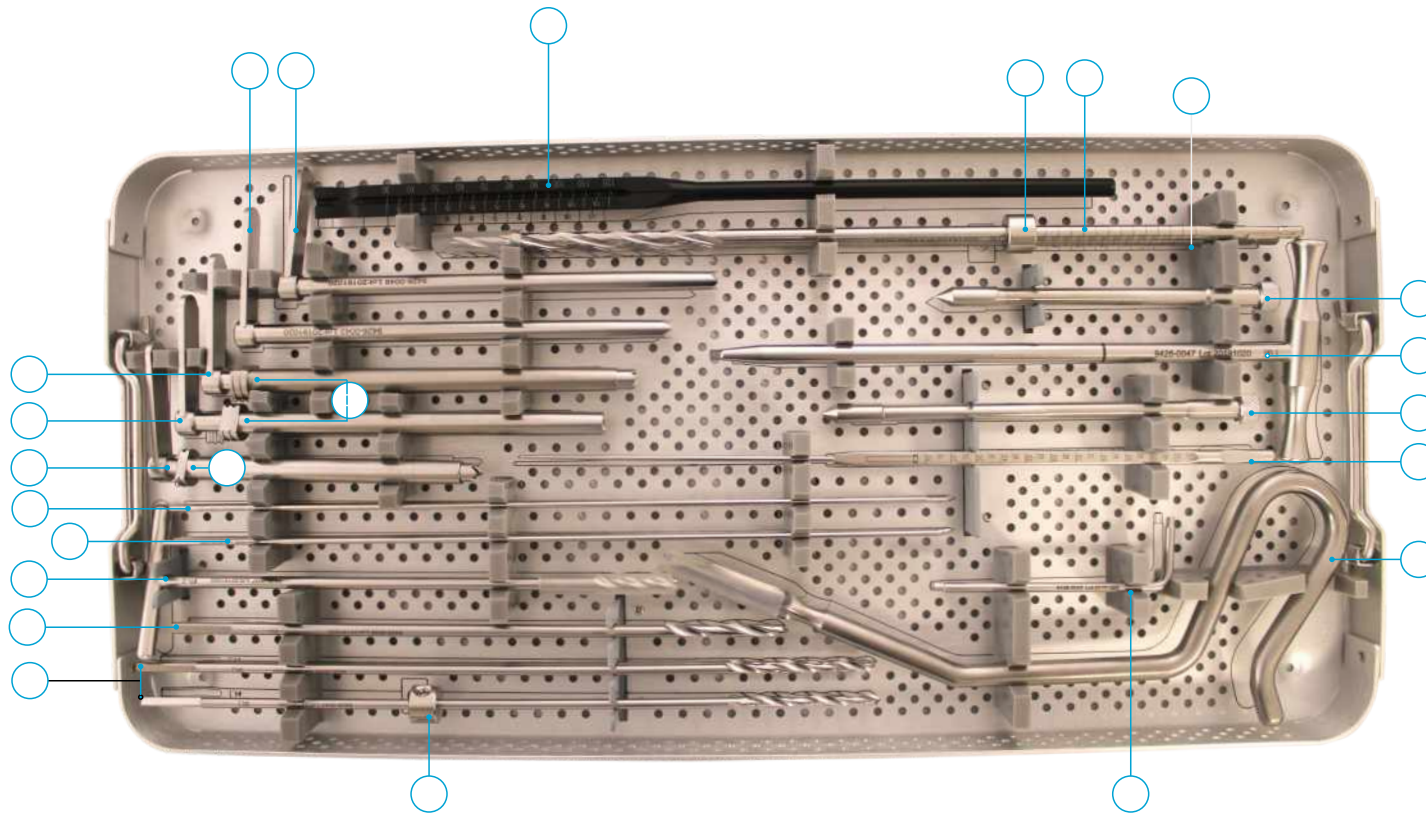

<b>C1</b>	Drill .Ø4.3/300mm	9426-0043
<b>C2</b>	Drill .Ø5.2/250mm	9426-0036
	T Drill Ø5.2mm	9426-0037
<b>C4</b>	Straight Kirschner Tel Ø2.5x315mm tip 1	9426-0050
<b>C5</b>	Grooved Kirschner Tel Ø2.5x315mm tip 2	9426-0051
	Dril Guide Ø5.2mm	9426-0035
	Centering Tube Ø10/Ø8.2mm/120mm	9426-0033
	Dril Guide Ø4.3mm	9426-0042
	Centering Tube 1 150mm	9426-0040
	Dril Guide Ø6.4mm	9413-0053
	Dril Guide Ø4.3mm	9426-0042
	Kirschner Guide Ø2.5mm	9426-0049
	Depth Guide	9413-0046
<b>C14</b>	Stoper Ø6.4mm SW3	9413-0056
<b>C15</b>	Lag Drill Ø6.4 mm	9413-0055
	Cannulated Lag Drill Ø6.4/Ø2.5mm	9413-0054
<b>C17</b>	Point Marker 140mm	9426-0041
<b>C18</b>	T Screwdriver SW.3.5	9426-0047
<b>C19</b>	Point Marker 175mm	9413-0034
<b>C20</b>	Depth Guide	9413-0052
<b>C21</b>	AWL	9413-0021
	L Wrench SW3	9413-0045
<b>C23</b>	Drill Stoper Ø4.3mm SW3	9413-0044



## 4.1 DEVICE CLEANING CONDITIONS

Do not use metal brushes or rubbing pads during Decontamination of the tools should be performed immediately after the surgical procedure is completed. Contaminated tools must not be allowed to dry before reprocessing.

Excessive blood or debris must be removed in order to prevent the drying on the surface. All users must be qualified staff with documented evidence of training and competence. Training should include the current guidelines, standards and hospital policies. Even if they are made of high-grade stainless steel, the surgical tools must be thoroughly dried in order to prevent rust formation. Prior to sterilization, all the tools should be examined for the cleanliness of the lumens of the joints of the surfaces. manual cleaning process. Use cleaning agents with low-foam surfactant to be able to see the tools in the cleaning solution. Rinse the cleaning materials easily from the tool in order to prevent residue formation.

pH enzymatic and cleaning materials are recommended for cleaning the reusable instruments. It is very important to neutralize and rinse the alkaline cleaning materials thoroughly from the tools. Anodized aluminum should not contact with certain cleaning or disinfectant solutions. Avoid strong alkaline cleaners and disinfectants and solutions containing iodine, chlorine or certain metal salts.

### 4.1.1 Manual Cleaning/Disinfection

Prepare the enzymatic and cleaning materials at the dilution rates and temperatures as recommended by the manufacturer. New solutions should be prepared when the existing solutions are heavily contaminated. Place the tools in the enzymatic solution so that they are completely immersed. Operate all the movable parts so that the detergent contacts with all the surfaces.

Keep in the fluid for minimum 20 min. Use a nylon, soft-bristled brush to gently rub the tools until all visible debris is cleaned. Pay particular attention to the accessible areas and use a suitable bottle brush. In order to remove the dirt in the open springs, coils or flexible parts, wash the recesses with plenty of cleaning solution. Rub the surface with a scrubbing brush to remove all the visible dirt from the surface and the recesses. To ensure that all the recesses are cleaned, turn the component while rubbing. Remove the tools and rinse them for minimum 3 min. under running water. Pay particular attention to the cannulas and use a syringe to pass the fluid through the hard-to-reach areas. Place all the tools that are completely immersed in water, in an ultrasonic unit containing the cleaning solution. Operate all the movable parts so that the detergent contacts with all the surfaces. Expose the tools to sonification process for minimum 10 min..

Remove the tools and rinse with deionized water for at least 3 minutes or unless all the blood or dirt traces are eliminated in the rinsing water. Examine the tools under normal light to verify that visible dirt is removed. If visible dirt is present, repeat the above mentioned sonification procedure and the rinsing steps. Remove the excessive moisture on the tool with a clean, absorbent, lint-free cloth.

### 4.1.2 Combination Manual / Automated Cleaning and Disinfection

Prepare the enzymatic and cleaning materials at the dilution rates and temperatures as recommended by the manufacturer. New solutions should be prepared when the existing solutions are heavily contaminated. Place the tools in the enzymatic solution so that they are completely immersed. Operate all the movable parts so that the detergent contacts with all the surfaces. Keep in the fluid for minimum 10 min. Use a nylon, soft-bristled brush to gently rub the tools until all visible debris is cleaned. Pay particular attention to the accessible areas and use a suitable bottle brush. A sonicator will help to clean the instruments thoroughly. The use of a syringe or a water fountain will facilitate passing of the liquid from the low-spaced areas and difficult-to-access areas. Remove the tools from the enzyme solution and rinse them for minimum 1 min. under deionized water. Place the tools in a suitable washer / disinfectant basket and perform a standard washer / disinfectant cycle. Specific minimum parameters are essential for a complete cleaning and disinfection. These parameters are given in a below mentioned table.

### 4.1.3 Automated Cleaning and Disinfection

Automated washing / drying systems are not recommended as the only cleaning method for surgical tools. An automated system can be used as a follow-up operation after manual cleaning. To ensure an effective cleaning, tools must be thoroughly examined before sterilization. For detailed information on Washing and Disinfection see

#### **Specific minimum parameters used for a complete cleaning and disinfection:**

	Definition
1	Pre-washing for 2 minutes with cold tap water
2	enzyme spray for 20 seconds with hot tap water
3	Immersion in enzyme after 1 minute
4	rinsing for 15 seconds with cold tap water (Should be repeated twice)
5	Washing with detergent for 2 minutes with hot tap water
6	rinsing for 15 seconds with hot tap water
7	Rinsing with 10 seconds with optional lubricated purified water
8	Drying for 7 minutes with hot air

Note: Follow the instruction of the washer/disinfectant manufacturer



### 5.1 Nail Size

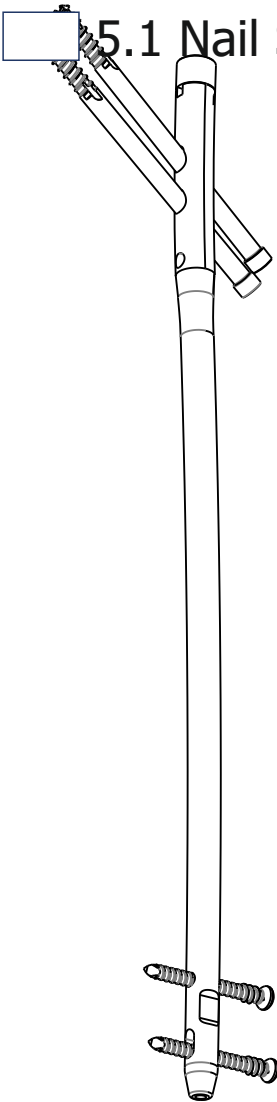

		RIGHT	LEFT	RIGHT	LEFT
4602-0918	9x180	4262-0932	9x320	4272-0932	9x320
4602-0920	9x200	4262-0934	9x340	4272-0934	9x340
4602-0922	9x220	4262-0936	9x360	4272-0936	9x360
4602-0924	9x240	4262-0938	9x380	4272-0938	9x380
4602-1018	10x180	4262-0940	9x400	4272-0940	9x400
4602-1020	10x200	4262-0942	9x420	4272-0942	9x420
4602-1022	10x220	4262-0944	9x440	4272-0944	9x440
4602-1024	10x240	4262-1032	10x 320	4272-1032	10x 320
4602-1118	11x180	4262-1034	10x 340	4272-1034	10x 340
4602-1120	11x200	4262-1036	10x 360	4272-1036	10x 360
4602-1122	11x220	4262-1038	10x 380	4272-1038	10x 380
4602-1124	11x240	4262-1040	10x 400	4272-1040	10x 400
4602-1218	12x180	4262-1042	10x 420	4272-1042	10x 420
4602-1220	12x200	4262-1044	10x 440	4272-1044	10x 440
4602-1222	12x220	4262-1132	11x 320	4272-1132	11x 320
4602-1224	12x240	4262-1134	11x 340	4272-1134	11x 340
4602-1318	13x180	4262-1136	11x 360	4272-1136	11x 360
4602-1320	13x200	4262-1138	11x 380	4272-1138	11x 380
4602-1322	13x220	4262-1140	11x 400	4272-1140	11x 400
4602-1324	13x240	4262-1142	11x 420	4272-1142	11x 420
4602-1418	14x180	4262-1144	11x 440	4272-1144	11x 440
4602-1420	14x200	4262-1232	12x 320	4272-1232	12x 320
4602-1422	14x220	4262-1234	12x 340	4272-1234	12x 340
4602-1424	14x240	4262-1236	12x 360	4272-1236	12x 360
		4262-1238	12x 380	4272-1238	12x 380
				4262-1240	12x 400
				4262-1242	12x 420
				4262-1244	12x 440
				4262-1332	13x 320
				4262-1334	13x 340
				4262-1336	13x 360
				4262-1338	13x 380
				4262-1340	13x 400
				4262-1342	13x 420
				4262-1344	13x 440
				4262-1432	14x 320
				4262-1434	14x 340
				4262-1436	14x 360
				4262-1438	14x 380
				4262-1440	14x 400
				4262-1442	14x 420
				4262-1444	14x 440
				4272-1240	12x 400
				4272-1242	12x 420
				4272-1244	12x 440
				4272-1332	13x 320
				4272-1334	13x 340
				4272-1336	13x 360
				4272-1338	13x 380
				4272-1340	13x 400
				4272-1342	13x 420
				4272-1344	13x 440
				4272-1432	14x 320
				4272-1434	14x 340
				4272-1436	14x 360
				4272-1438	14x 380
				4272-1440	14x 400
				4272-1442	14x 420
				4272-1444	14x 440

## 5.2 Proximal Ø4.8 Screw

If fracture is only on shaft or distal place of the femur there is no need to use lag screw. In stead of lag screw, Ø4.8 screw is preferred. The purpose of this is fixed the nail on the proximal it could be prevent from rotation. First of all nail is stabilized from distal with devices. And then Ø4.8 screw is send.

