



[www.zimed.com.tr](http://www.zimed.com.tr)



**Ostéo France Ortho**

5.00  
Locking

# PROXIMAL LATERAL TIBIAL L PLATE

Surgical Technique

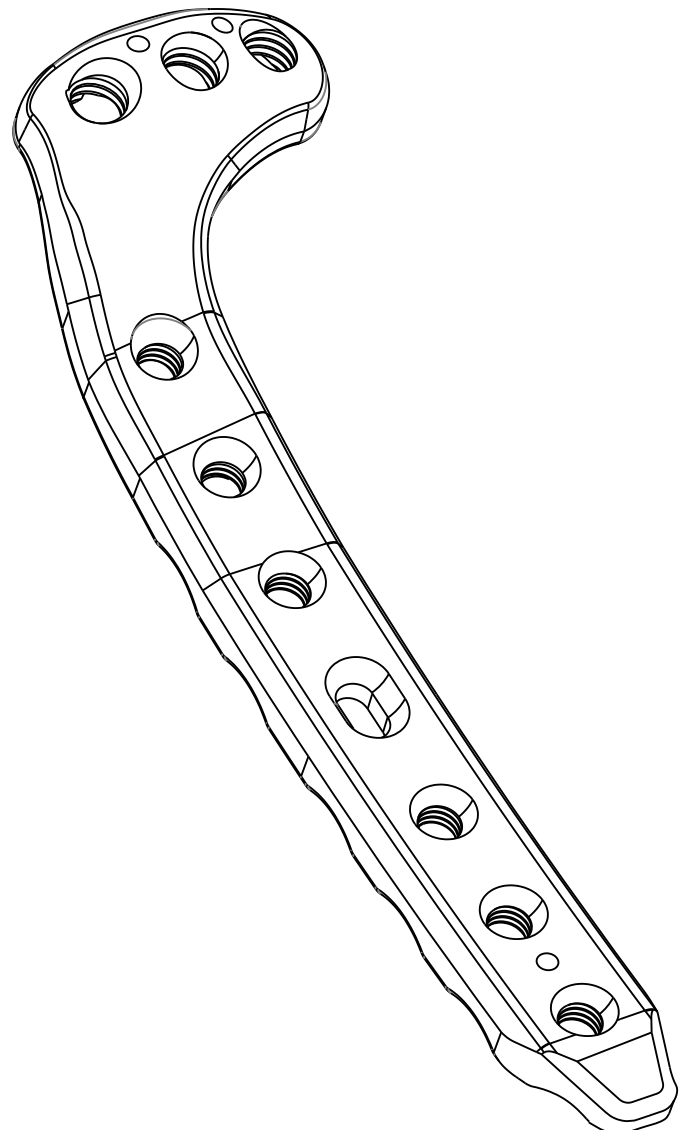

**Ostéo France Ortho**



## CONTENS

Locking

# PROXIMAL LATERAL TIBIAL L PLATE

## 1. Introduction

1.1.Locking Proximal Tibial L Plate.....	3
1.1.1.Specification .....	

## 2. Surgical Technique

2.1.Approach.....	4
2.1.1.Anterolateral approach to the proximal tibia.....	
2.2.Fracture.....	4
2.2.1.Fracture types.....	
2.3.Proximal Tibial L Plate.....	5
2.3.1.Plate Placement.....	
2.3.1.1Starting with cortical sciew from shaft.....	
2.3.1.2.Starting from proximal.....	
2.3.1.3.Cancellous Screw.....	
2.3.1.4.Cortical Screw.....	
2.3.1.5.Locking Screw.....	

## 3. Screw

3.1. Ø5.0 mm Locking, Ø4.5 mm Cortical, Ø6.5 mm Cancellous Screw.....	9
---	---

## 4. Instrument Set

4.1. 5.0 Instrument Set.....	10
4.2. Tray 1.....	
4.2. Tray 2-3.....	

## 4. Disinfection

5.1. Device Cleaning Conditions.....	11
5.1.1. Manual Cleaning/Disinfection.....	
5.1.2. Combination Manual / Automated Cleaning.....	
and Disinfection:.....	
5.1.3. Automated Cleaning and Disinfection.....	

**zimed**<sup>®</sup>

ISO 9001:2015  
ISO 13485:2016





## 1.1.Locking Proximal Tibial L Plate

### 1.1.1.Specifications

Proximal Medial Tibial L Plate is indicated for fractures of trochanteric region, trochanterodiaphyseal, proximal and shaft fractures, malunion / nonunion and proximal tibia osteotomies. Used with Ø5mm locking screw, Ø4,5 cortical screw and Ø6,5 cancellous screw. 8, 10, 12, 14, 16 hole right and left length options are available. The plate is made of titanium material produced according to ISO 5832-2.

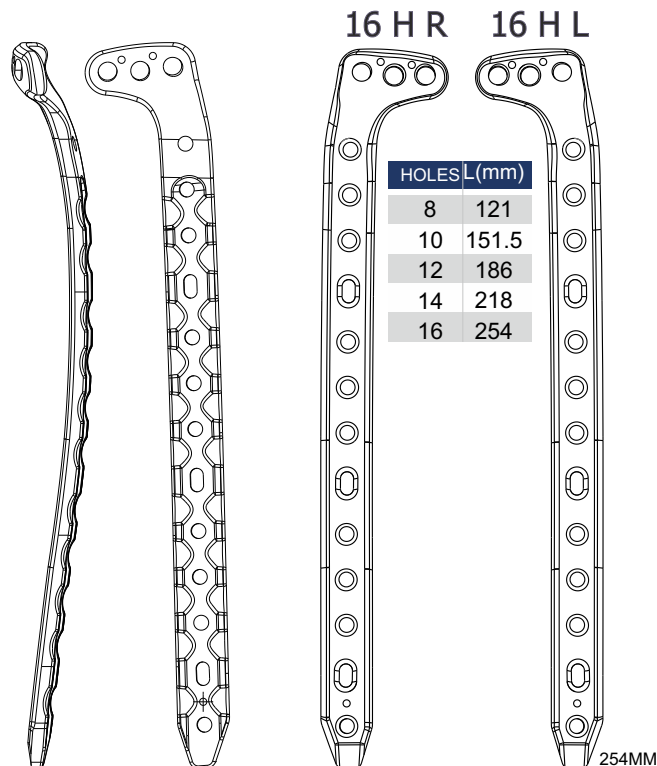

# zimed®

Locking  
PROXIMAL LATERAL  
TIBIAL L PLATE  
(with Ø 5,0, / Ø 4,5/ Ø 6,5 mm screw)

REF. NO	HOLES
1822-1008	8-R
1822-1010	10-R
1822-1012	12-R
1822-1014	14-R
1822-1016	16-R
1822-2008	8-L
1822-2010	10-L
1822-2012	12-L
1822-2014	14-L
1822-2016	16-L

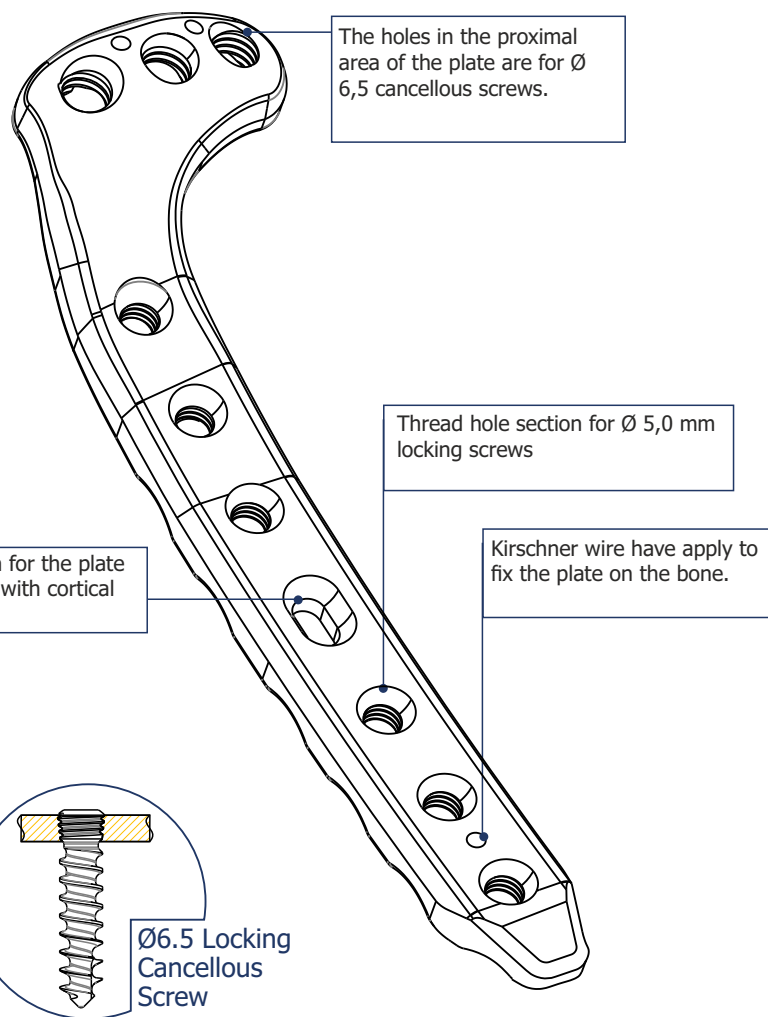



## 2.1. Approach

### 2.1.1. Anterolateral approach to the proximal tibia

Anterolateral approach can be used for this plate application. (Fig. 1)

Avoid the peroneal nerve that runs behind the biceps femoris tendon where it attaches to the head of the fibula. Caution Do not attempt to expose the postero-medial side of the tibia from the anterolateral approach.

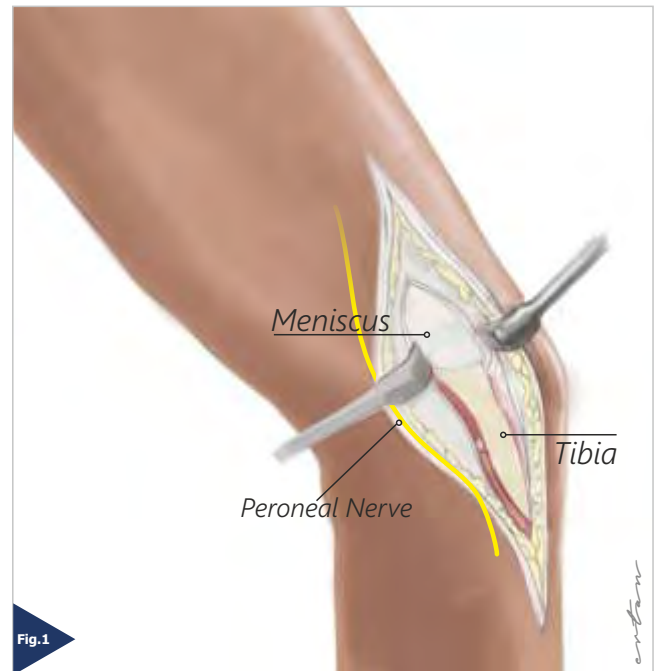

## 2.2. Fracture

### 2.2.1. Fracture types



Metaphyseal simple



Partial articular fracture, split



Partial articular fracture, split depression



Complete articular fracture, simple articular, simple metaphyseal

It can be applied to various fractures in the tibia. For each of the tibia fracture types to which the plate will be applied, fracture reduction may be required with various methods before the application. Depending on the form of the fracture, a second plate may be required medially. For example (Fig.2) due to displacement and (Fig.5) a second plate application from the medial side may be needed.



## 2.3. Proximal Tibial L Plate

### 2.3.1. Plate Placement

#### 2.3.1.1 Starting with cortical screw from shaft

Initial fixation can be made for the plate whose location is determined using the neutral hole on the plate with the cortical screw (Fig.6). Minor adjustments can be made proximal and distally using the neutral hole. then the cortical screw is tightened (Fig.7-8). The plate was temporarily fixed by attaching Kirshner wires proximally. Canned screws can be sent followed by locking screws.

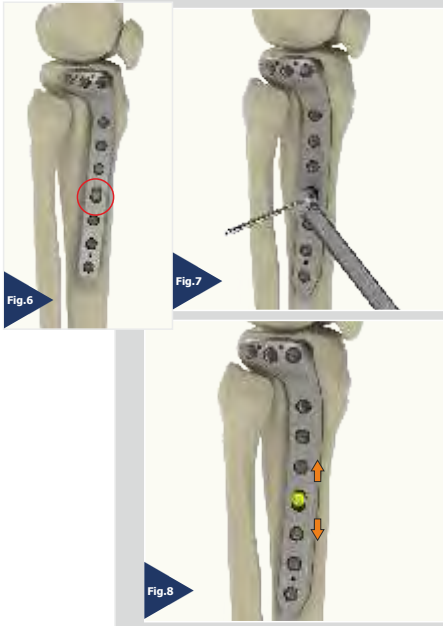

#### 2.3.1.2 Starting from proximal

Guides are first attached to the plate for placement in this way. (Fig.9)

#### 2.3.1.2 Starting from proximal



Plate placement is done by holding the guides (Fig.10)

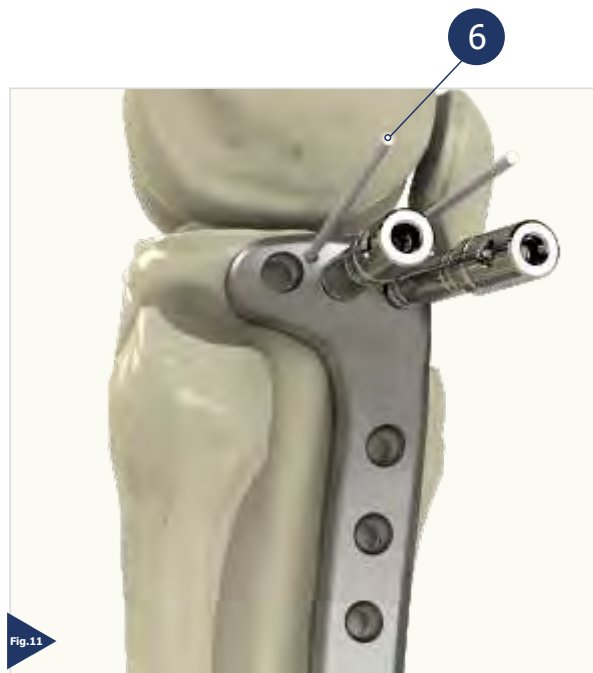

After the location of the plate is determined, a temporary fixation is made by attaching Kirshner wires (6). (Fig.11)



## 2.3. Proximal Tibial L Plate

### 2.3.1.3. Cancellous Screw

The plate is temporarily fixed proximally.  $\varnothing 6.5\text{mm}$  cancellous screws can be sent.

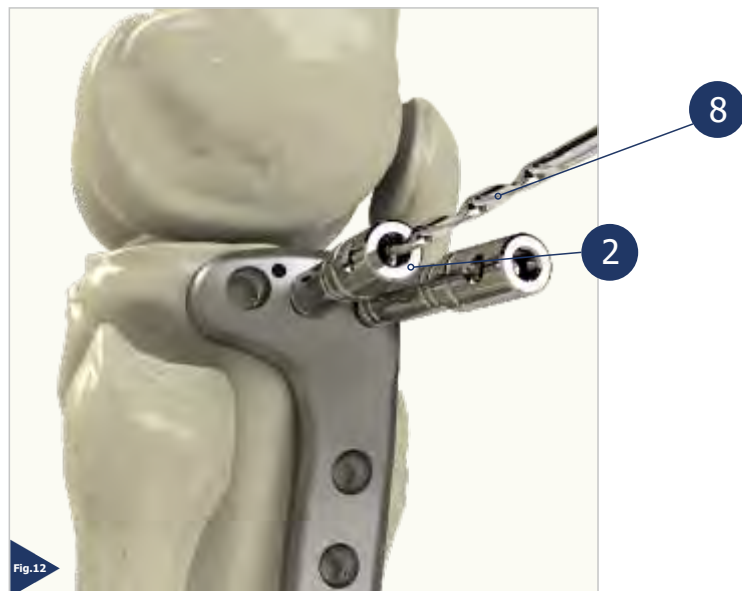

(8) Drilling is done from the guides (2). (Fig. 12)

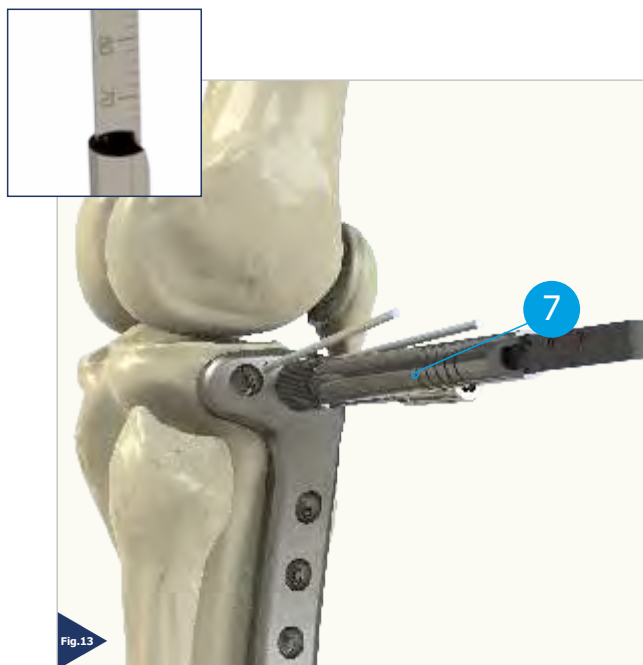

Screw length is determined. (7) (Fig. 13)



Cancellous screws (13) of which the length is determined are sent with a screwdriver. (Fig. 15)



## 2.3. Proximal Tibial L Plate

### 2.3.1.4. Cortical Screw

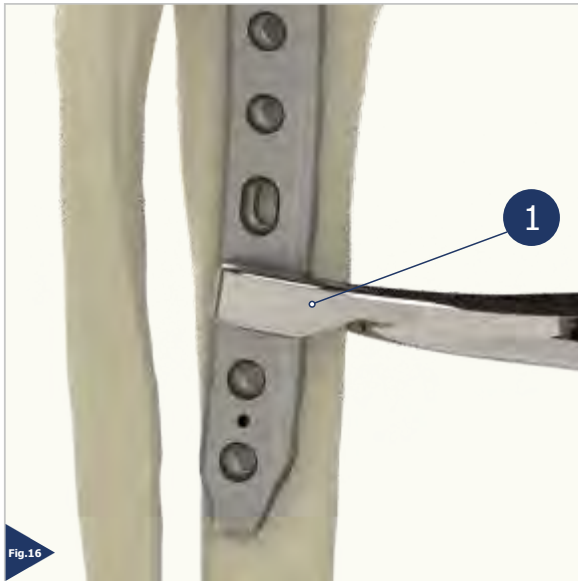

In order to bring the plate closer to the bone in the shaft area, the plate and the bone holder (1) are turned and compressed from the shaft area (Fig. 16).

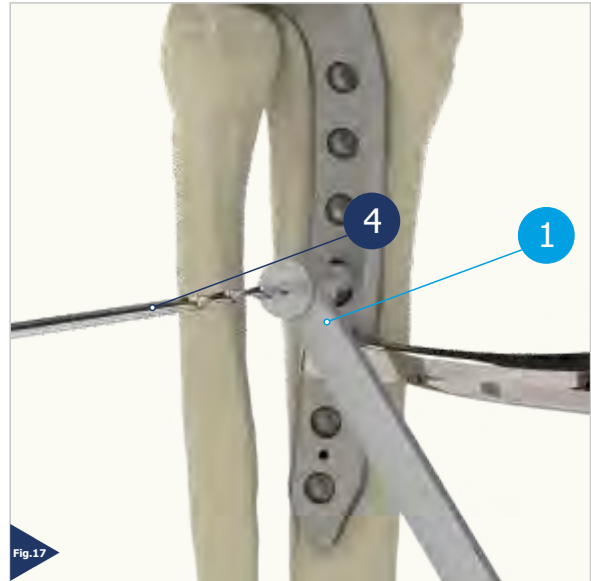

For the cortical screw, use the double-sided drill guide (1). Drill (4). (Use the double-sided guide's pilot hole designed for the neutral hole. (Fig. 17).

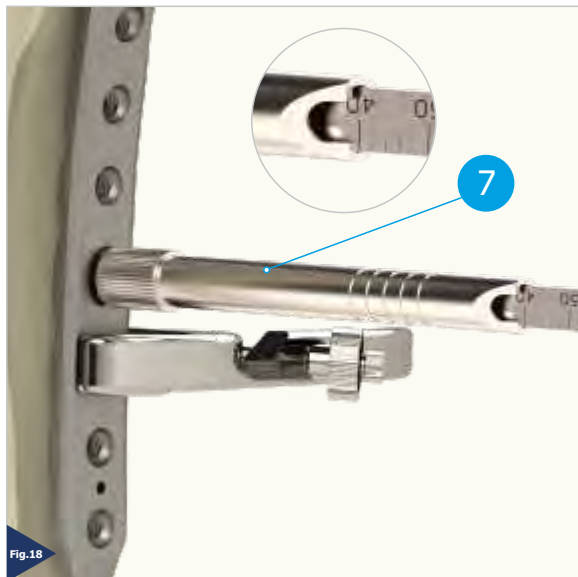

The length of the cortical screw is determined by the length meter (7) (Fig. 18)

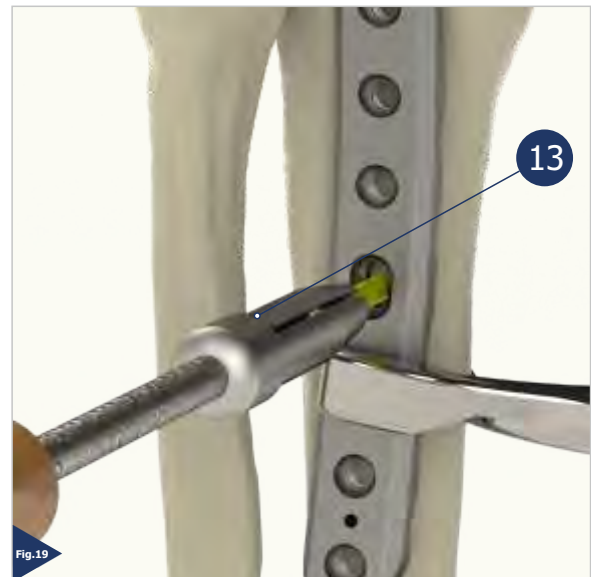

The cortical screw is attached with a screwdriver (13). (Fig. 19)



## 2.3. Proximal Tibial L Plate

### 2.3.1.4. Locking Screw



Fig. 20

In this way, the plate is fixed proximally and distally. Locking screw can be switched. (Fig. 20)

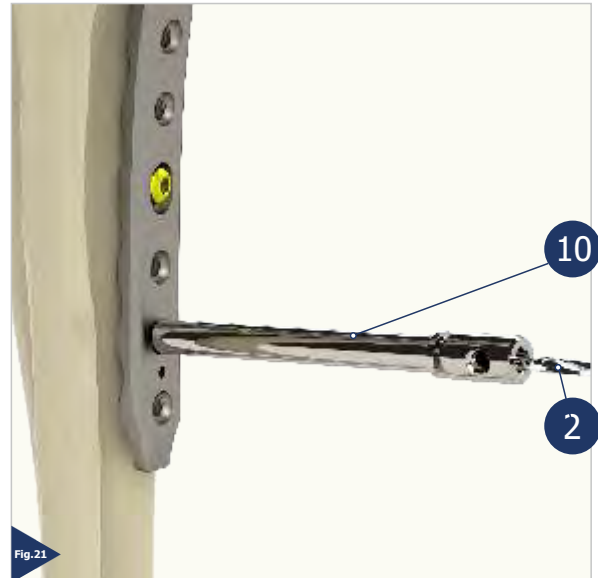

Fig. 21

Drill (2) using the guide (10) for the locking screw. (Fig. 21)

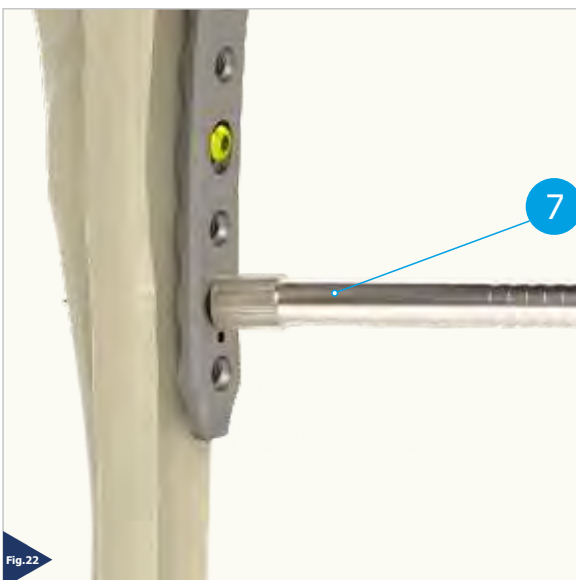

Fig. 22

Measure the height with the height meter (7). (Fig. 22)

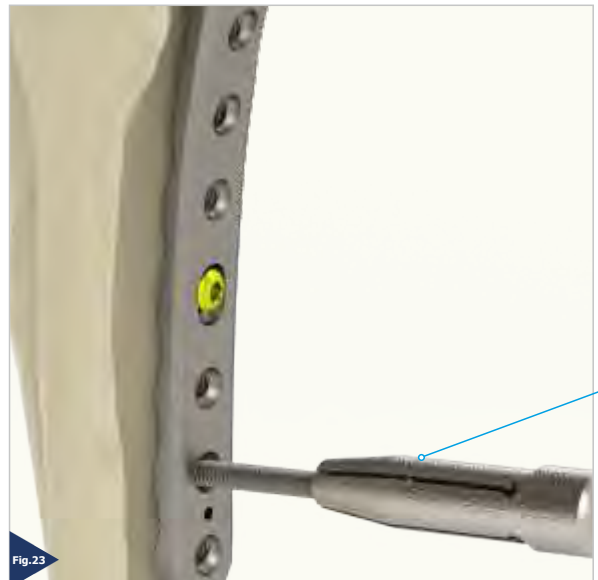
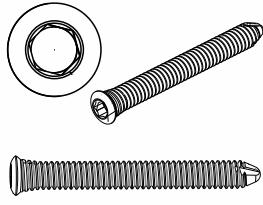

Fig. 23

Send the locked screws of which size is determined, with a screwdriver (13). Determine the number of screws according to the plate length. At least 3 locking screws should be sent. (Fig. 23)



### 5,0 Locking Screw



REF. NO	SIZE
2052-5012	12
2052-5014	14
2052-5016	16
2052-5018	18
2052-5020	20
2052-5022	22
2052-5024	24
2052-5026	26
2052-5028	28
2052-5030	30
2052-5032	32
2052-5034	34
2052-5036	36
2052-5038	38
2052-5040	40
2052-5042	42
2052-5044	44
2052-5046	46
2052-5048	48
2052-5050	50
2052-5052	52
2052-5054	54
2052-5055	55
2052-5056	56
2052-5058	58
2052-5060	60
2052-5065	65
2052-5070	70
2052-5075	75
2052-5080	80
2052-5085	85
2052-5090	90
2052-5095	95

### 4,5 Cortical Screw

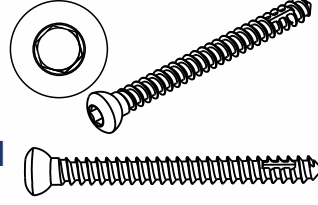

REF. NO	SIZE
2012-4512	4.5x12
2012-4514	4.5x14
2012-4516	4.5x16
2012-4518	4.5x18
2012-4520	4.5x20
2012-4522	4.5x22
2012-4524	4.5x24
2012-4526	4.5x26
2012-4528	4.5x28
2012-4530	4.5x30
2012-4532	4.5x32
2012-4534	4.5x34
2012-4536	4.5x36
2012-4538	4.5x38
2012-4540	4.5x40
2012-4542	4.5x42
2012-4544	4.5x44
2012-4546	4.5x46
2012-4548	4.5x48
2012-4550	4.5x50
2012-4552	4.5x52
2012-4554	4.5x54
2012-4556	4.5x56
2012-4558	4.5x58
2012-4560	4.5x60
2012-4565	4.5x65
2012-4570	4.5x70
2012-4575	4.5x75
2012-4580	4.5x80
2012-4585	4.5x85
2012-4590	4.5x90

### 6,5 Cancellous Screw

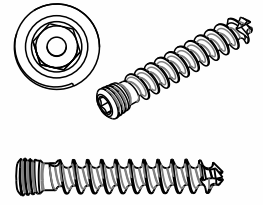

REF. NO	SIZE
2182-0030	6.5x30
2182-0035	6.5x35
2182-0040	6.5x40
2182-0045	6.5x45
2182-0050	6.5x50
2182-0055	6.5x55
2182-0060	6.5x60
2182-0065	6.5x65
2182-0070	6.5x70
2182-0075	6.5x75
2182-0080	6.5x80
2182-0085	6.5x85
2182-0090	6.5x90
2182-0095	6.5x95
2182-0100	6.5x100
2182-0105	6.5x105
2182-0110	6.5x110
2182-0115	6.5x115
2182-0120	6.5x120

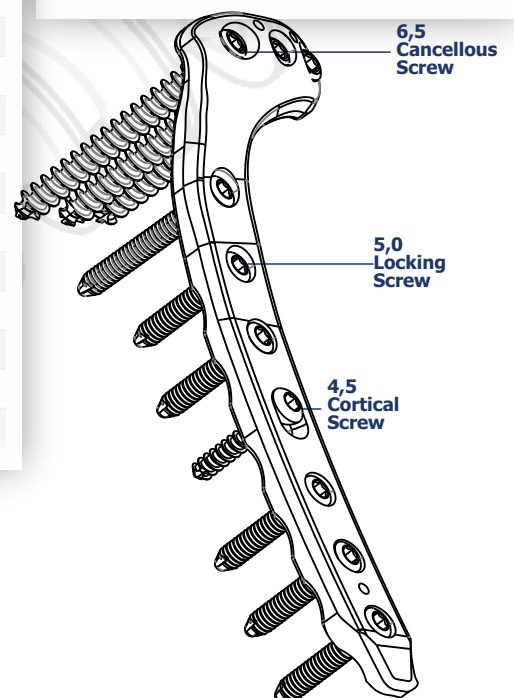



# zimed<sup>®</sup>

Large Fragment Locking  
Plate Instrument Set

5,0<sub>mm</sub>



ISO 9001:2015  
ISO 13485:2016



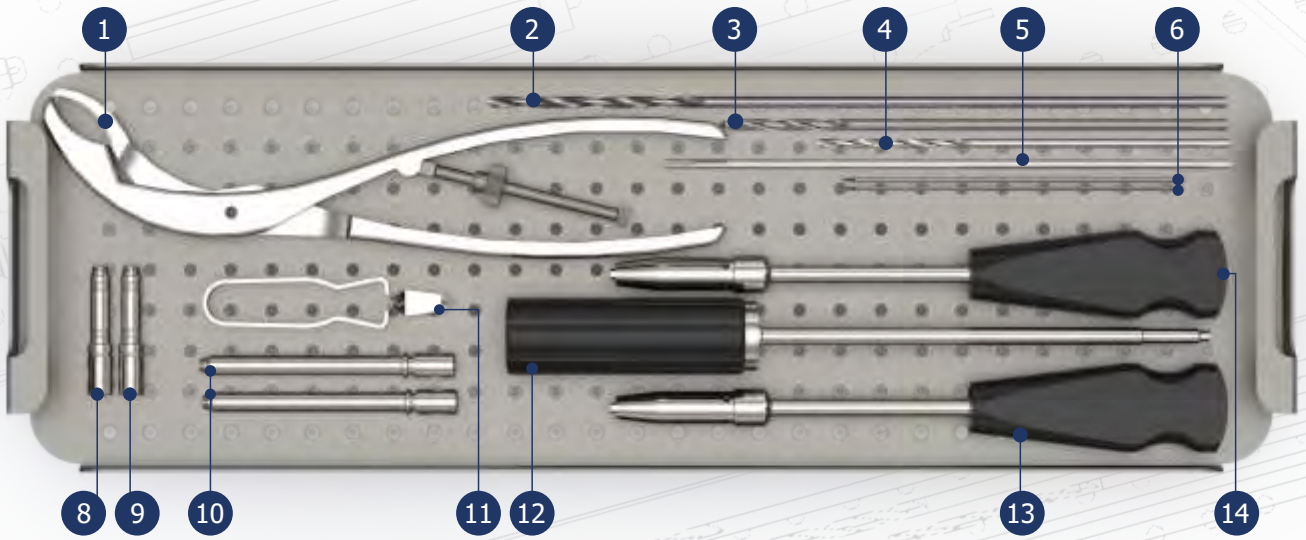

1	9102-0013	Bone holding forceps	8	9102-0026	Drill Guide Ø 4,5 mm
2	9102-0021	Drill Ø 4,3 x 220 mm	9	9102-0032	Drill Guide Ø 4,5 mm
3	9102-0020	Drill Ø 3,2 x 160 mm	10	9102-0019	Drill Guide Ø 4,3
4	9102-0022	Drill Ø 4,5 mm	11	9102-0018	Screw Holder
5	9102-0023	Threaded Guide Ø 2,3 mm	12	9102-0010	Torque Limiting Screwdriver 4.0 Nm
6	9702-0080	Kirschner Wires	13	9102-0005	Screwdriver Ø 3.5 mm
7			14	9102-0002	Star Screwdriver T25

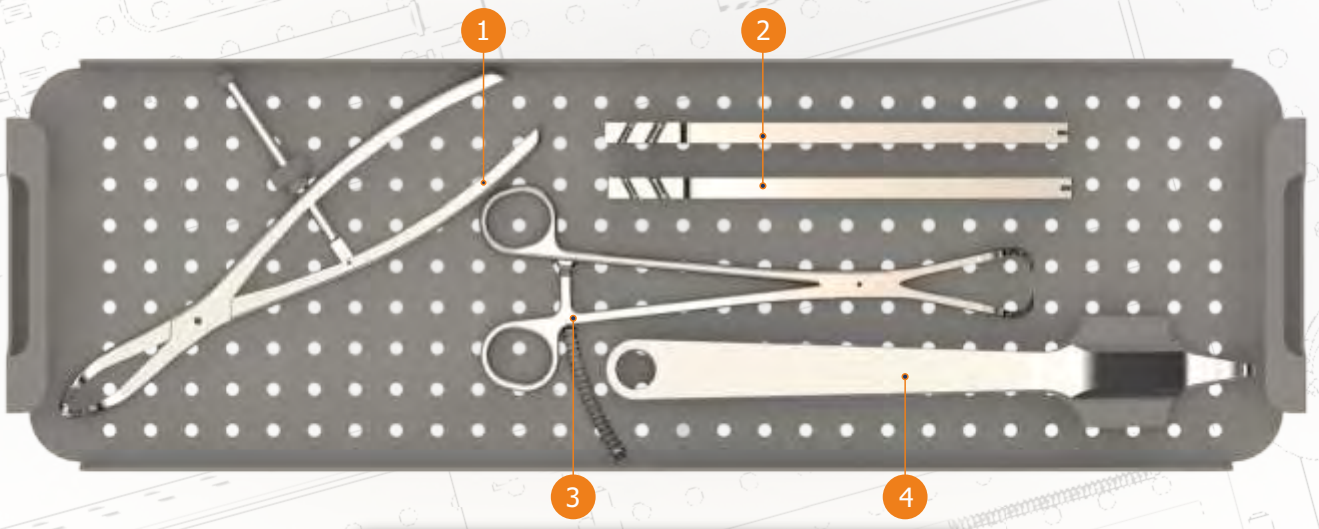

1	9102-0011	Reduction Forceps
2	9102-0001	Plate Bender
3	9102-0012	Reduction Forceps with Points
4	9102-0009	Retractor Large

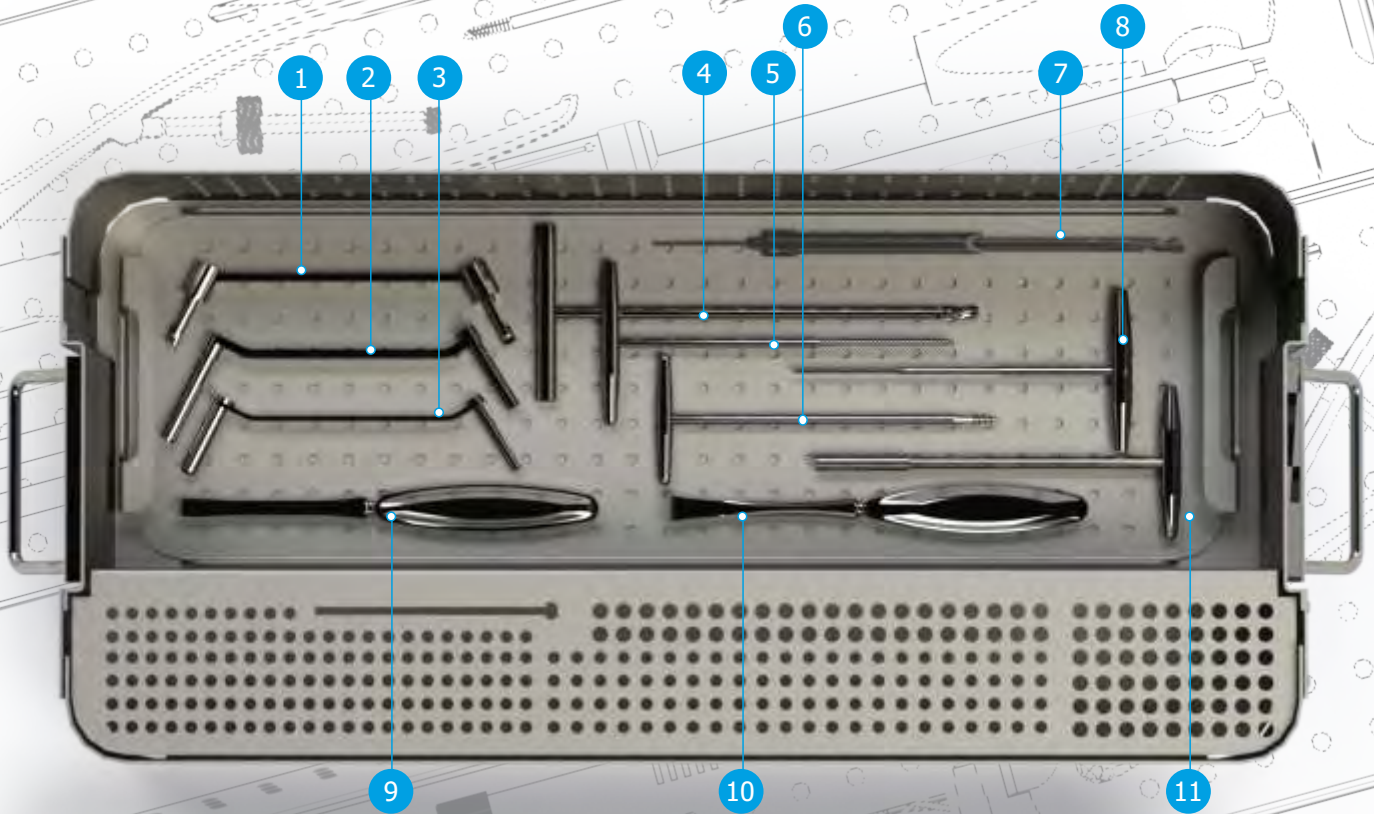

<b>1</b>	9102-0055	Double Drill Guide Ø 4,5 Ø 6,5 mm
<b>2</b>	9102-0056	Double Drill Guide Ø 3.2 (Angled Tube)
<b>3</b>	9102-0057	Double Drill Guide Ø 3.2 (Straight Tube)
<b>4</b>	9102-0024	Tap Ø 6.5 mm (for Cancellous Screw)
<b>5</b>	9102-0024	Tap Ø 6.5 mm (for Cancellous Screw)
<b>6</b>	9102-0017	Screw Extractor

<b>7</b>	9102-0007	Depth Guide
<b>8</b>	9102-0025	Tap Ø 4.5 mm (For Cortical Screw)
<b>9</b>	9102-0004	Bone Scraper Small 5,0 mm
<b>10</b>	9102-0003	Bone Scraper Large 5,0 mm
<b>11</b>	9102-0030	Bone Reamer 5,0 mm



## 5.1 DEVICE CLEANING CONDITIONS

Do not use metal brushes or rubbing pads during Decontamination of the tools should be performed immediately after the surgical procedure is completed. Contaminated tools must not be allowed to dry before reprocessing.

Excessive blood or debris must be removed in order to prevent the drying on the surface. All users must be qualified staff with documented evidence of training and competence. Training should include the current guidelines, standards and hospital policies. Even if they are made of high-grade stainless steel, the surgical tools must be thoroughly dried in order to prevent rust formation. Prior to sterilization, all the tools should be examined for the cleanliness of the lumens of the joints of the surfaces. manual cleaning process. Use cleaning agents with low-foam surfactant to be able to see the tools in the cleaning solution. Rinse the cleaning materials easily from the tool in order to prevent residue formation.

Mineral oil or silicon lubricants should not be used

materials are recommended for cleaning the reusable instruments. It is very important to neutralize and rinse the alkaline cleaning materials thoroughly from the tools. Anodized aluminum should not contact with certain cleaning or disinfectant solutions. Avoid strong alkaline cleaners and disinfectants and solutions containing iodine, chlorine or certain metal salts.

### 5.1.1 Manual Cleaning/Disinfection

Prepare the enzymatic and cleaning materials at the dilution rates and temperatures as recommended by the manufacturer. New solutions should be prepared when the existing solutions are heavily contaminated. Place the tools in the enzymatic solution so that they are completely immersed. Operate all the movable parts so that the detergent contacts with all the surfaces.

Keep in the fluid for minimum 20 min. Use a nylon, soft-bristled brush to gently rub the tools until all visible debris is cleaned. Pay particular attention to the accessible areas and use a suitable bottle brush. In order to remove the dirt in the open springs, coils or flexible parts, wash the recesses with plenty of cleaning solution. Rub the surface with a scrubbing brush to remove all the visible dirt from the surface and the recesses. To ensure that all the recesses are cleaned, turn the component while rubbing. Remove the tools and rinse them for minimum 3 min. under running water. Pay particular attention to the cannulas and use a syringe to pass the fluid through the hard-to-reach areas. Place all the tools that are completely immersed in water, in an ultrasonic unit containing the cleaning solution. Operate all the movable parts so that the detergent contacts with all the surfaces. Expose the tools to sonification process for minimum 10 min..

Remove the tools and rinse with deionized water for at least 3 minutes or unless all the blood or dirt traces are eliminated in the rinsing water. Examine the tools under normal light to verify that visible dirt is removed. If

visible dirt is present, repeat the above mentioned sonification procedure and the rinsing steps. Remove the excessive moisture on the tool with a clean, absorbent, lint-free cloth.

### 5.1.2 Combination Manual / Automated Cleaning and Disinfection

Prepare the enzymatic and cleaning materials at the dilution rates and temperatures as recommended by the manufacturer. New solutions should be prepared when the existing solutions are heavily contaminated. Place the tools in the enzymatic solution so that they are completely immersed. Operate all the movable parts so that the detergent contacts with all the surfaces. Keep in the fluid for minimum 10 min. Use a nylon, soft-bristled brush to gently rub the tools until all visible debris is cleaned. Pay particular attention to the accessible areas and use a suitable bottle brush. A sonicator will help to clean the instruments thoroughly. The use of a syringe or a water fountain will facilitate passing of the liquid from the low-spaced areas and difficult-to-access areas. Remove the tools from the enzyme solution and rinse them for minimum 1 min. under deionized water. Place the tools in a suitable washer / disinfectant basket and perform a standard washer / disinfectant cycle. Specific minimum parameters are essential for a complete cleaning and disinfection. These parameters are given in a below mentioned table.



### 5.1.3 Automated Cleaning and Disinfection

Automated washing / drying systems are not recommended as the only cleaning method for surgical tools. An automated system can be used as a follow-up operation after manual cleaning. To ensure an effective cleaning, tools must be thoroughly examined before sterilization. For detailed information on Washing and Disinfection see

#### **Specific minimum parameters used for a complete cleaning and disinfection:**

	Definition
1	Pre-washing for 2 minutes with cold tap water
2	enzyme spray for 20 seconds with hot tap water
3	Immersion in enzyme after 1 minute
4	rinsing for 15 seconds with cold tap water (Should be repeated twice)
5	Washing with detergent for 2 minutes with hot tap water
6	rinsing for 15 seconds with hot tap water
7	Rinsing with 10 seconds with optional lubricated purified water
8	Drying for 7 minutes with hot air

Note: Follow the instruction of the washer/disinfectant manufacturer

●  **Osteo France Ortho** Medical, as the manufacturer of this device, and their surgical consultants do not recommend this or any other surgical technique for use on a specific patient. The surgeon who performs any implant procedure is responsible for determining and utilizing the appropriate techniques for implanting the device in each individual patient.  **Osteo France Ortho** surgical consultants are not responsible for selection of the appropriate surgical technique to be utilized for an individual patient.